

SaniForce™ Pneumatic Controls

3A6101B
EN

Integrated Pneumatic Controls for use with Hygienic Unloader Systems. For professional use only.



Important Safety Instructions

Read all warnings and instructions in this manual and the system manuals. **Save all instructions.**

*Maximum Working Air Pressure: 100
psi (0.7 MPa, 6.9 bar)*

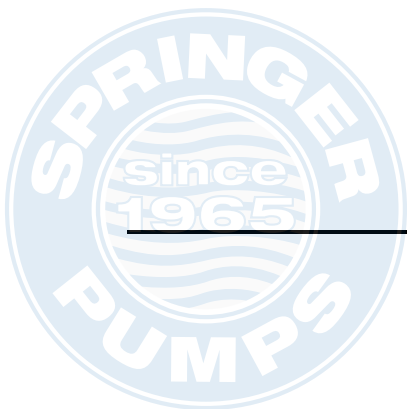
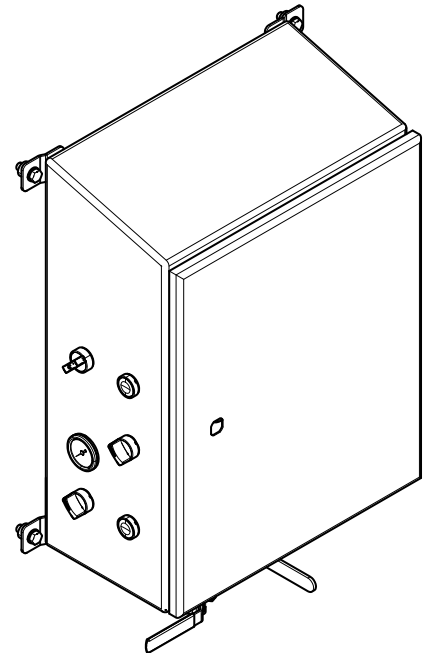

PROVEN QUALITY. LEADING TECHNOLOGY.

Contents

Models.....	2	25C578 Parts	6
Pressure Relief Procedure	3	25C543 Parts	14
Switch Replacement	5		

Models

Model Number	Description
25C578	Pneumatic control panel, STU
25C543	Pneumatic control panel, SDU



Pressure Relief Procedure



Follow the Pressure Relief Procedure whenever you see this symbol.

<p>This equipment stays pressurized until pressure is relieved manually. To help prevent serious injury from injection, pinching, or crushing, follow the Pressure Relief Procedure before you clean, check, or service the equipment.</p>				

1. Follow the Pressure Relief Procedure in the system operation manual where this control panel is installed to place the system in a safe maintenance position before servicing the equipment.
2. Turn off air supply valves, BV1 & BV2, located on the bottom of the control panel.



3A6101B

Tel: 866-777-6060
Fax: 866-777-6383

Springer Pumps, LLC

Website: www.springerpumps.com
Int'l: +001 267 404 2910

Switch Replacement

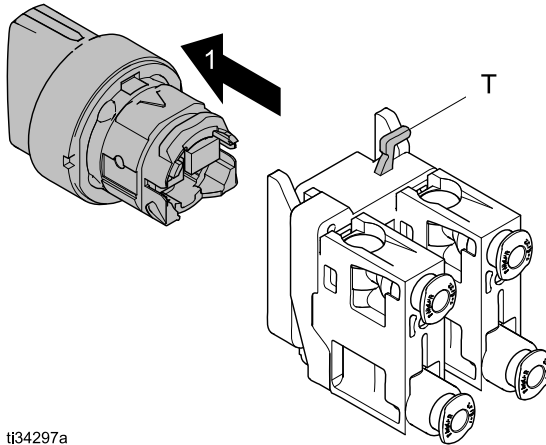
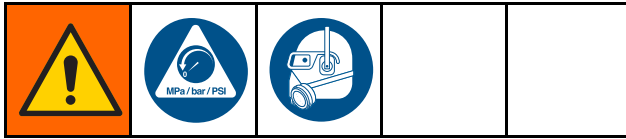

ti34297a

To remove a switch from the control panel:

1. Perform the pressure relief procedure.
2. Loosen the tension screw on the switch body (opposite side of switch body from tab T).
3. Remove switch knob from switch body by lifting tab (T) and moving knob in direction 1.
4. The switch body is now free of the mounting surface of the panel.

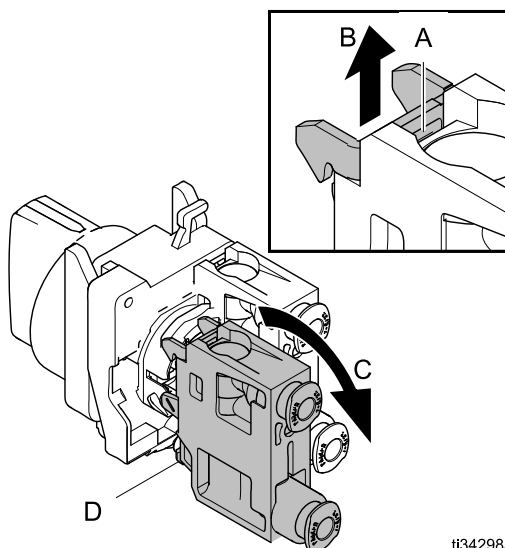

ti34298a

To remove a pneumatic valve from a switch:

1. Perform the pressure relief procedure.
2. Release spring-loaded latch on valve by inserting a small flat-blade screwdriver in A and move the latch in direction B.
3. Rotate the valve in direction C.
4. The bottom tab (D) provides the pivot for removal or installation of the valve on the switch body.



25C578 Parts

Control Panel 25C578

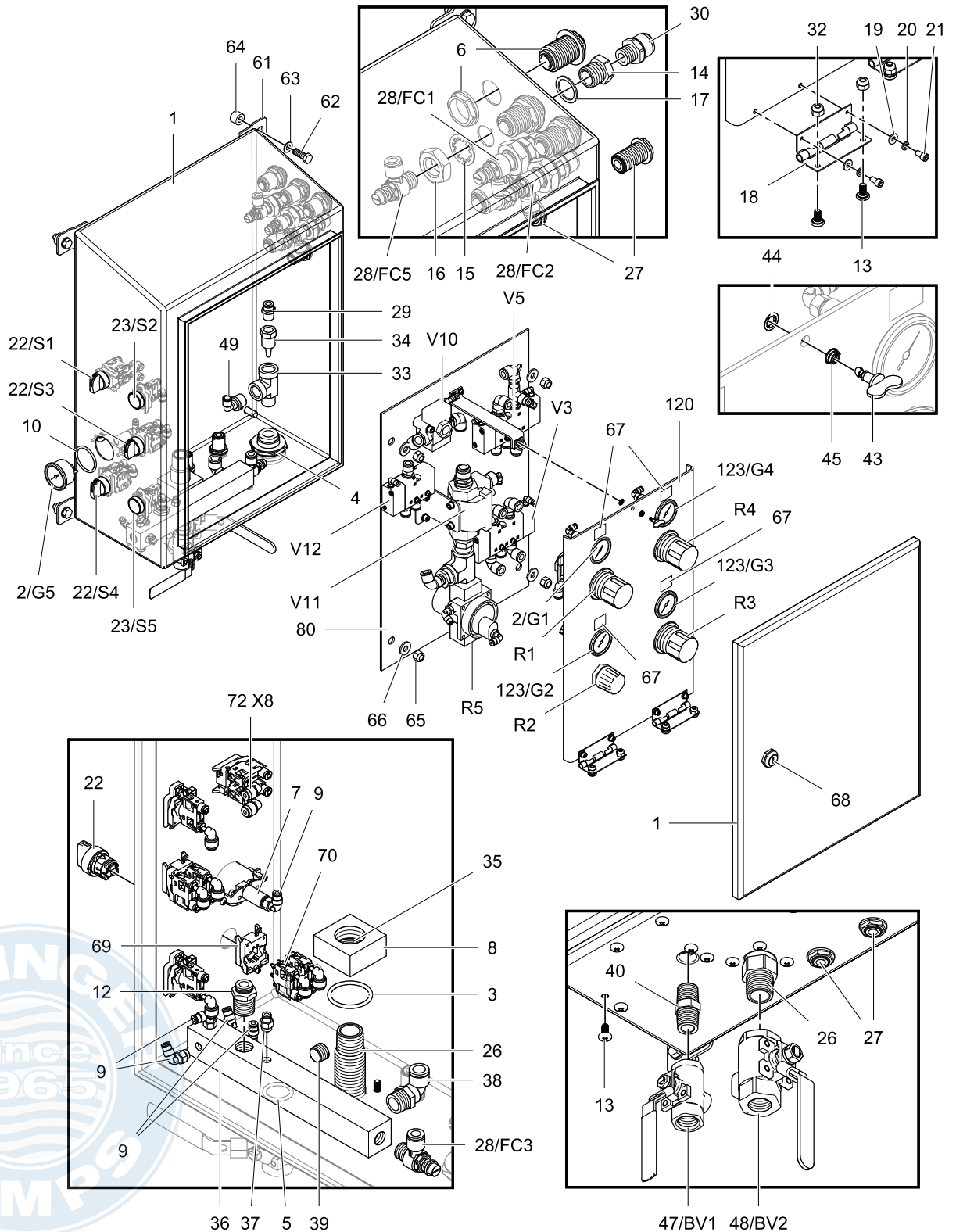

132840a

Control Panel 25C578

Ref.	Part/Kit	Description	Qty.
1	17U557	ENCLOSURE	1
2	16V725	GAUGE, 0-30 psi	2
3	156593	O-RING, #222	1
4	16Y981	FITTING, bulkhead, 1/2 npt	1
5	C20195	O-RING, #213	1
6	16Y995	FITTING, bulkhead, 1/2 tube	4
7	100451	COUPLING	1
8	17S086	BLOCK, air control	1
9	114151	FITTING, elbow, swivel	6
10	114054	O-RING, #222 FMK	1
11	17T017	FITTING, elbow, 3/8T x 3/8 stem	1
12	16G247	FITTING, 1/2 npt x 3/8 tube	1
13	17T272	SCREW, seal	14
14	191586	FITTING, 3/8 npt	3
15	113348	WASHER, lock	3
16	111014	NUT, jam	3
17	17V668	WASHER	3
18	17T271	HINGE	2
19	102360	WASHER, flat	4
20	100020	WASHER, lock	4
21	104371	SCREW, 10 x 0.375	4
22	17W584	SWITCH, 3 position	3
23	17W582	BUTTON, push	2
26	17S085	FITTING, 3/4 npt x 4 5/8	1
27	17P903	BULKHEAD	3
28	17T098	VALVE 3/8 npt x 3/8 tube	4
29	114485	FITTING	1
30	17T103	FITTING	4
32	109478	NUT	4
33	124844	FITTING tee	1
34	17S738	NOZZLE	1
35	154662	O-RING	1
36	17S087	MANIFOLD	1
37	114263	FITTING	1
38	15V204	FITTING, elbow, 1/2 npt x 1/2 tube	1

Ref.	Part/Kit	Description	Qty.
39	101754	PLUG	2
40	114373	FITTING, nipple	1
43	17T520	LATCH, 1/4 turn	1
44	17T523	RETAINER, 1/4 turn	1
45	17T524	SPRING, 1/4 turn	1
47	16Y861	VALVE, ball, vented, 1/2 in.	1
48	17T519	VALVE, ball, vented, 3/4 in.	1
49	C38211	FITTING, tube	1
51	123988	FITTING, 1/2 x 3/8 tube	1
52	17V624	FITTING, tee	2
53	17V626	FITTING, tee	1
54	17V625	FITTING	2
55	17Y406*	TUBE, 3/8 O.D.	6 ft
56	17Y407*	TUBE, 1/2 O.D.	15 ft
57	17Y408*	TUBE, 0.156 O.D.	6 ft
58	113281	VALVE, OR gate	3
59	17A251	FITTING, reducer, 1/4 to 5/32	1
60	617569	FITTING, reducer	1
61	17T422	BRACKET, foot, pack of 4	1
62	102471	SCREW, 3/8-16 x 1.0	4
63	104034	WASHER	4
64	17T873	SPACER, 3/8 x 0.5	4
65	101566	NUT	4
66	100023	WASHER	4
67	17W450	LABEL SET	1
68	17U123	KEY, latch	1
69	17W585	BLOCK, mounting	5
70	17W586	VALVE, switch	8
72	17A240	FITTING, elbow, 5/32	8
80	---	PANEL, air controls, see page 8	1
120	---	PANEL, component, see page 10	1

* Part number represents a 6 foot length of replacement tube.

Air Controls Panel

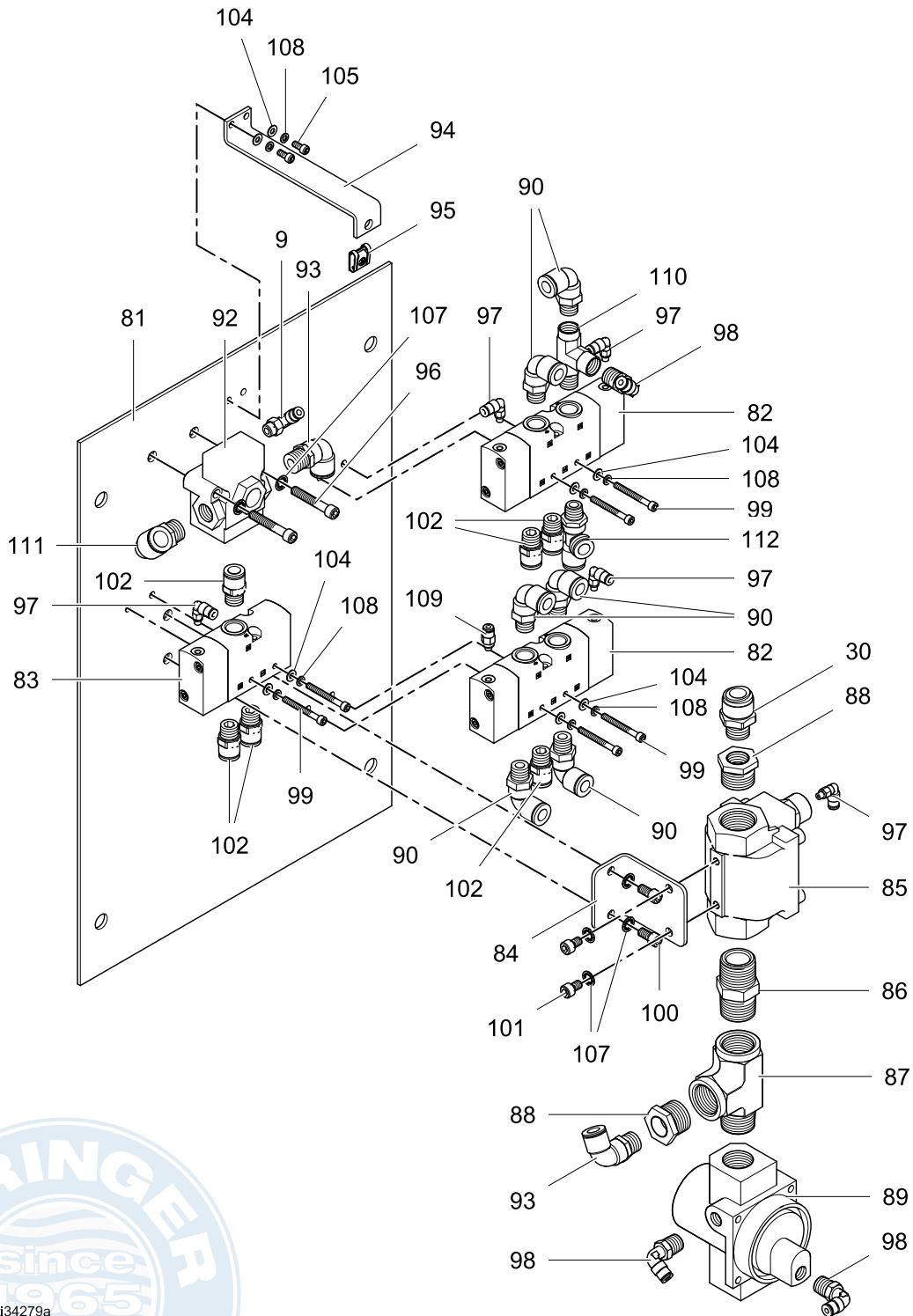

Air Controls Panel

Ref.	Part/Kit	Description	Qty.
81	17S206	PANEL	1
82	17T009	VALVE	2
83	17T002	VALVE	1
84	17T274	BRACKET	1
85	17T007	VALVE	1
86	119992	FITTING, nipple, 3/4 x 3/4 npt	1
87	111337	FITTING, tee	1
88	100505	BUSHING	2
89	17P434	REGULATOR, 5-160 psi	1
90	121141	FITTING, elbow, swivel	6
92	17P440	VALVE	1
93	16F151	FITTING, elbow, 3/8 tube x 3/8 npt	2
94	17S084	BRACKET, latch	1
95	17T522	CLIP, 1/4 turn	1
96	596936	SCREW, 1/4 x 1.25	2

Ref.	Part/Kit	Description	Qty.
97	110460	FITTING	5
98	114469	FITTING, elbow, swivel	3
99	C19977	SCREW, cap	6
100	101550	SCREW, cap	2
101	116899	SCREW	2
102	120389	FITTING, tube	6
104	107584	WASHER	8
105	103229	SCREW	2
107	100028	WASHER, lock	6
108	100079	WASHER, lock, spring	8
109	111328	CONNECTOR	1
110	556420	FITTING, tee	1
111	121212	FITTING, elbow, 1/2 tube x 3/8 mnpt	1
112	C38157	FITTING, tee	1



3A6101B

Tel: 866-777-6060
Fax: 866-777-6383

Springer Pumps, LLC

Website: www.springerpumps.com
Int'l: +001 267 404 2910

Component Panel

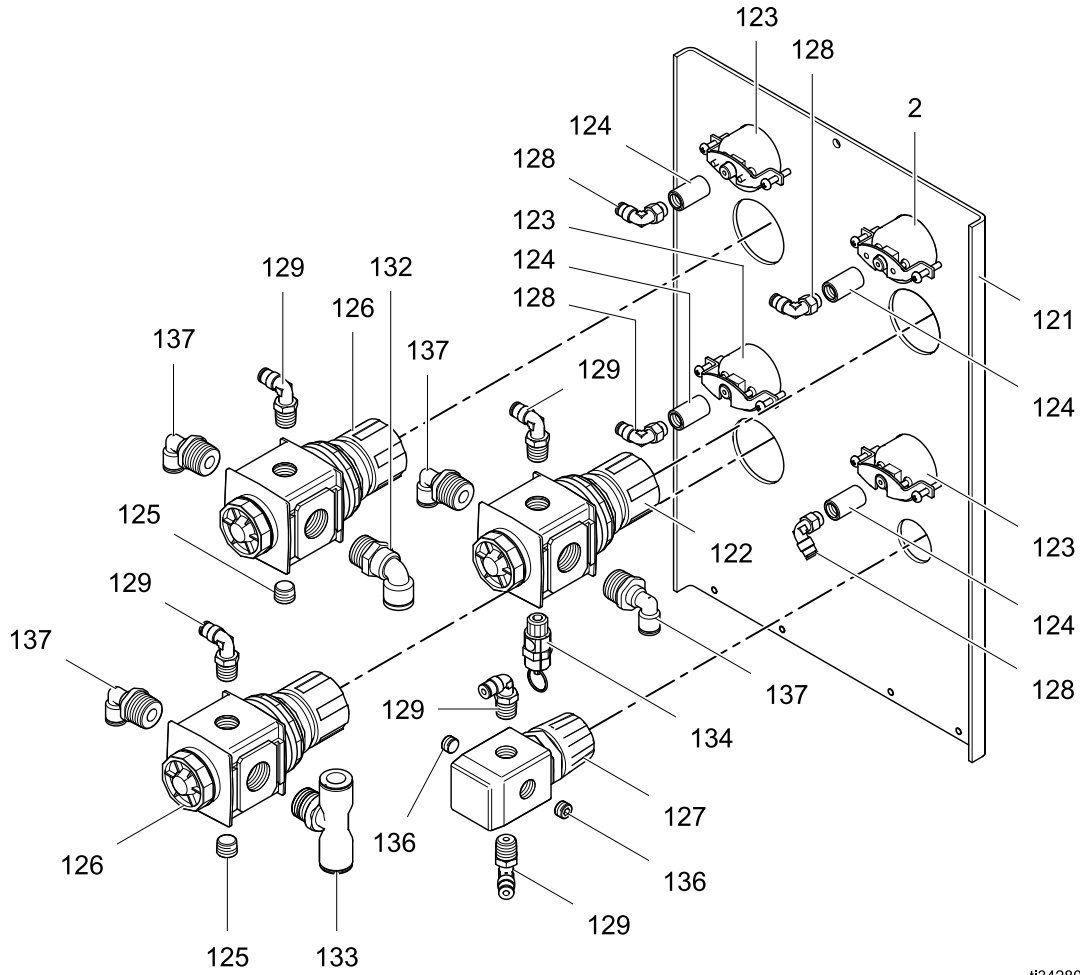

ti34280a

Component Panel

Ref.	Part/Kit	Description	Qty.
121	17S088	PANEL	1
122	17T269	REGULATOR	1
123	16V727	GAUGE, 0-160 psi	3
124	100451	COUPLING	4
125	100721	PLUG	2
126	16T410	REGULATOR	2
127	120432	REGULATOR	1
128	114151	FITTING, elbow, swivel	4

Ref.	Part/Kit	Description	Qty.
129	114469	FITTING, elbow, swivel	5
132	15V204	FITTING, elbow, 1/2 npt x 1/2 tube	1
133	17G678	FITTING, tee, 1/2 tube	1
134	117480	VALVE, relief, 26 psi	1
136	104765	PLUG	2
137	C38211	FITTING	4

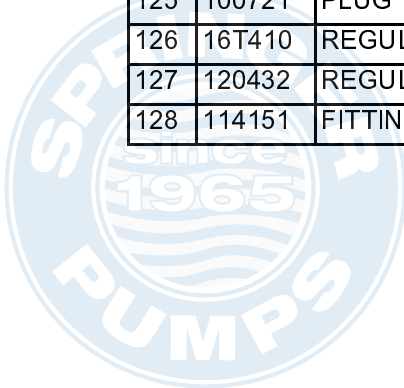

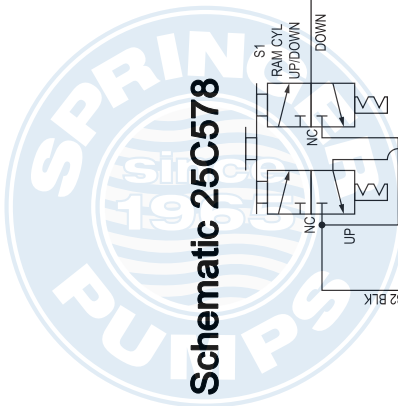

Schematic 25C578

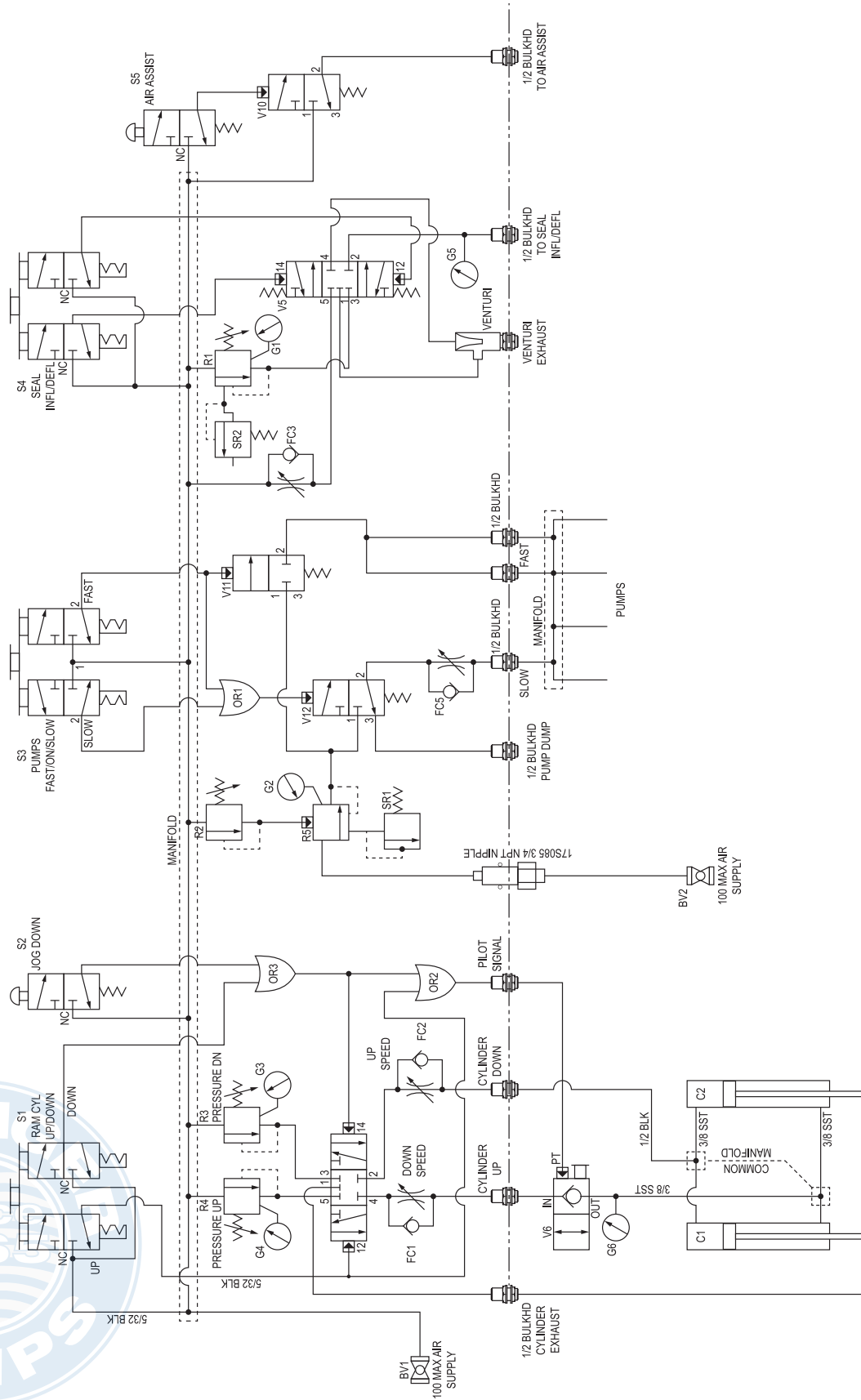

3A6101B

Tel: 866-777-6060
 Fax: 866-777-6383

Springer Pumps, LLC

Website: www.springerpumps.com
 Int'l: +001 267 404 2910

25C578 Tubing Routing

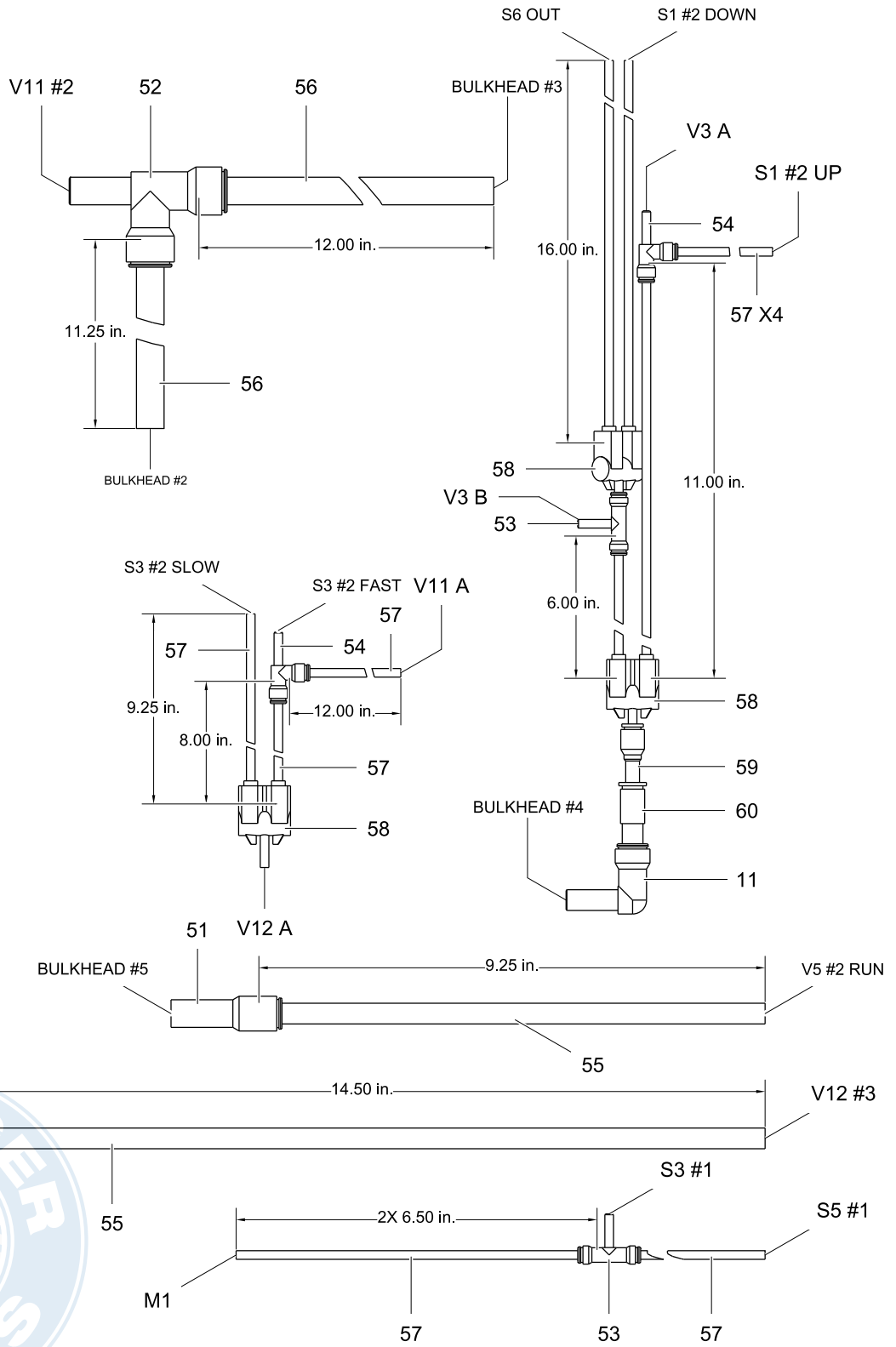

Tubing requiring additional fittings.

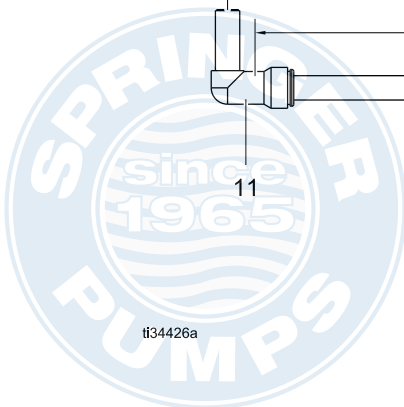

Single Tubes			
TUBE PART NO.	LENGTH (inches)	FROM	TO
56	15.5	V10 #2	Bulkhead #1
56	10.75	M8	R3 IN
56	6.0	R3 IN	R4 IN
55	10.5	FC1	V3 #2
55	11.5	FC2	V3 #4
55	18.25	FC5	V12 #2
55	15.25	Venturi #1	V5 #4
55	11.25	Venturi #2	V5 #1
55	13.25	FC3	V5 #5
55	19.0	R1 OUT	V5 #3 Branch
55	11.5	R3 OUT	V3 #5
55	17.25	R4 OUT	V3 #3
55	6.0	R5 OUT	V12 #1
55	15.5	M4	R1 IN
55	13.5	V5 #3 RUN	V10 #1
55	5.0	V3 #1	Bulkhead #7
57	22.5	G5	V5 #2 Branch
57	4.0	R1 Gauge	G1
57	12.5	R5 Gauge	G2
57	4.0	R3 Gauge	G3
57	4.0	R4 Gauge	G4
57	3.25	M2	S1 #1
57	5.25	M3	S4 #1
57	6.75	R2 OUT	R5 A
57	17.5	S5 #2	V10 A
57	16.0	S4 #2	V5 A
57	20.75	S4 #2	V5 B
57	11.0	M6	R2 IN
57	14.0	M10	S6

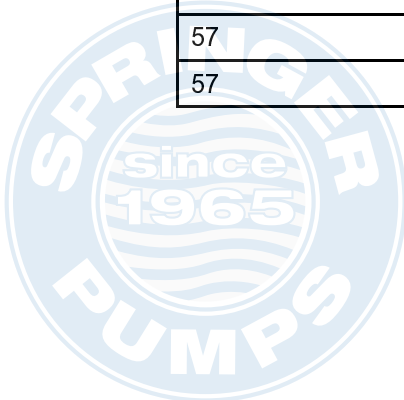

25C543 Parts

Control Panel 25C543

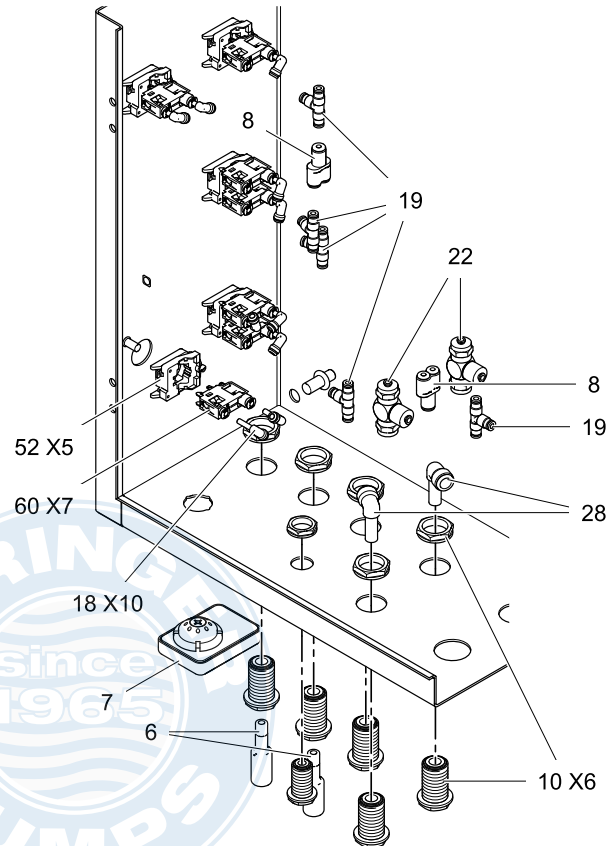
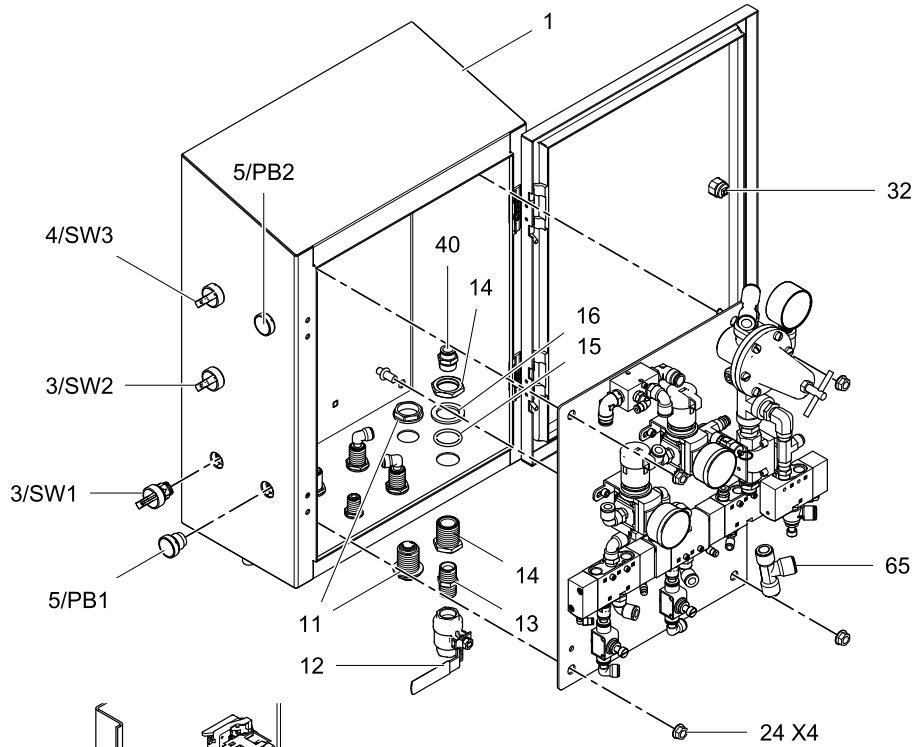

Control Panel 25C578

1134578a

Ref.	Part/Kit	Description	Qty.
1	17P914	ENCLOSURE	1
2	25C542	PANEL	1
3	17W584	SWITCH, 3 position	2
4	17W583	SWITCH, 2 position	1
5	17W582	BUTTON, push	2
6	17T407	MUFFLER	2
7	17T405	VENT, breather	1
8	125418	FITTING, Y, 5/32 tube	2
10	17P903	BULKHEAD, 3/8 in. tube	6
11	16Y995	FITTING, bulkhead, 1/2 in. tube	1
12	17X891	VALVE, ball, 1/2 in. vented	1
13	158491	FITTING, nipple	2
14	17P901	BULKHEAD, 1/2 NPT	1
15	154662	O-RING	1
16	17P900	WASHER, flat	1
17	17W764	GAUGE, 0-60 psi	2
18	17X848	FITTING, elbow, 5/32	10
19	125417	FITTING, tee, 0.156 tube	5
20	115968	SCREW, cap	6
21	17T002	VALVE, pump prime	3
22	17X847	VALVE, shuttle	2
23	206197	REGULATOR	1
24	112958	NUT, 3/8-16	4
25	17X707	VALVE, main pump	1
26	17X852	BRACKET, mounting	1
27	103229	SCREW, cap	2
28	123986	FITTING, elbow, 3/8 tube	4
29	17T009	VALVE, main, ram	1
30	17X709	REGULATOR, unloader	2
31	556420	FITTING, tee, 1/4FP x 1/4MP	2
32	17U123	KEY, latch	1
33	110460	FITTING, elbow, swivel, 10-32 x 5.32	6

Ref.	Part/Kit	Description	Qty.
35	120389	FITTING, tube	2
36	114316	FITTING, elbow, swivel	1
37	070274	TAPE, TFE	AR
38	114469	FITTING, elbow, swivel	1
39	124844	FITTING, tee, 1/2NPT(M) x 1/2NPT(F) x 1/2NPT(F)	1
40	114111	FITTING, connector, male	2
41	114114	FITTING, elbow, swivel	1
42	S67178	FITTING, elbow, 90 1/4 NPT(F)	1
43	17X710	BRACKET, regulator	2
44	117480	VALVE, relief, 26 psi	1
45	156971	FITTING, nipple	2
46	121141	FITTING, elbow, swivel, 3/8 tube x 1/4 NPT(M)	9
47	100721	PLUG, pipe	2
50	C19977	SCREW, cap	2
51	17G678	FITTING, tee, 1/2 tube	1
52	17W585	BLOCK, mounting	5
53	C19407	FITTING	2
54	123249	FITTING, elbow, 1/4NPT	1
55	118574	FITTING, reducer, 1/2 x 1/4	1
57	17X850	VALVE, flow control	2
60	17W586	VALVE, switch	7
62	101550	SCREW, cap	4
63	17T008	VALVE, flow control	1
65	17X849	FITTING, tee, 1/2 x 1/2 x 3/8	1
66	17V333	GAUGE, 0-100 psi	1
67	054760	TUBE, 1/2 in.	3 ft
68	054941	TUBE, 3/8 in.	6 ft
69	054130	TUBE, 1/4 in.	1 ft
70	154734	TUBE, 0.156 in.	11 ft

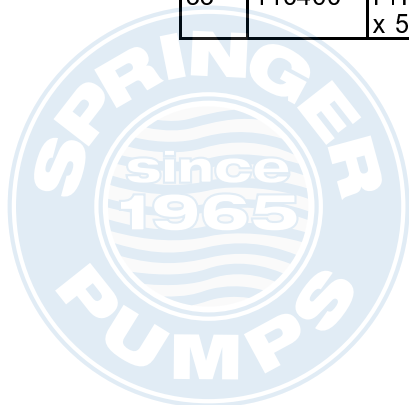

Component Panel 25C542

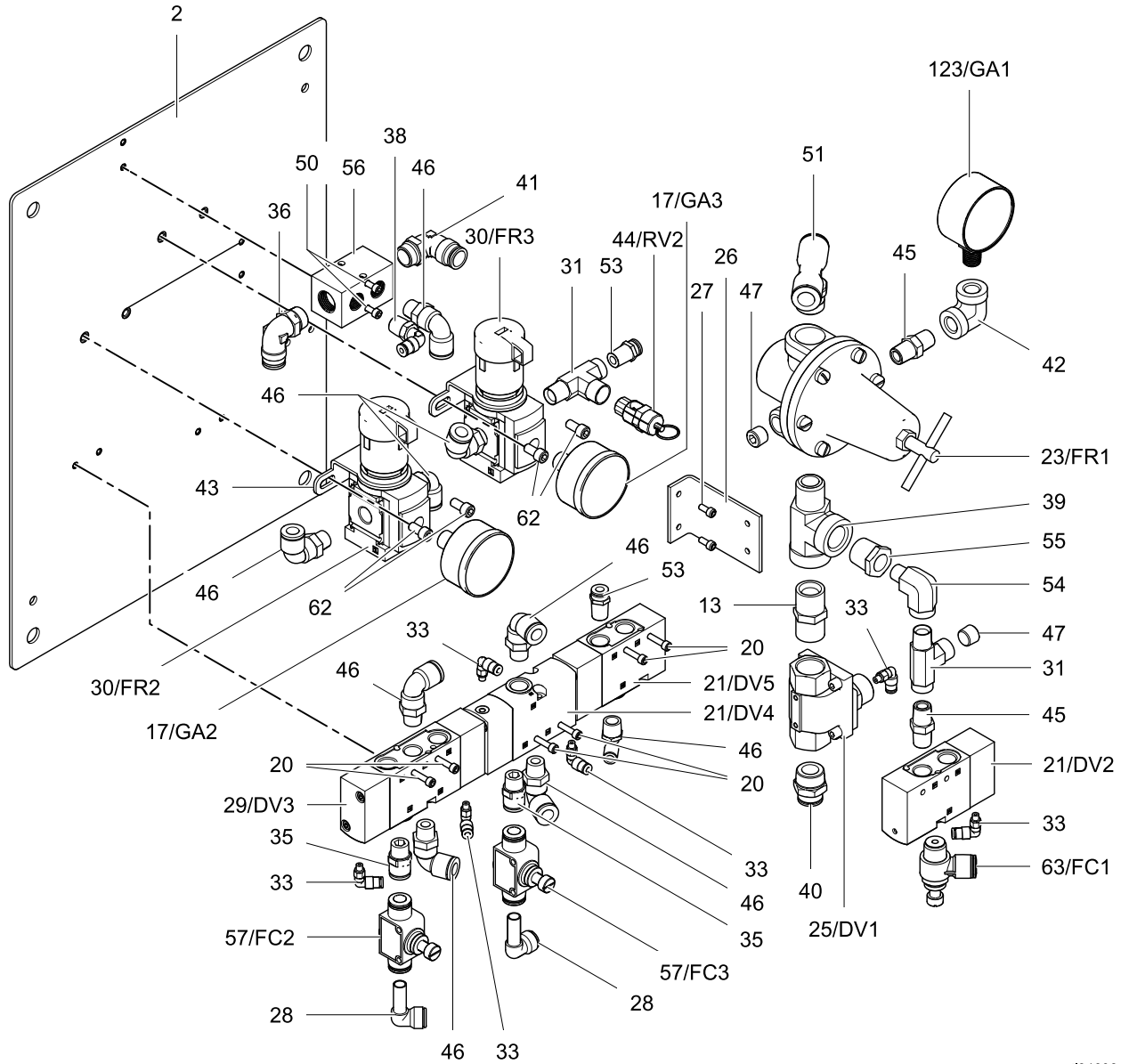

ti34606a



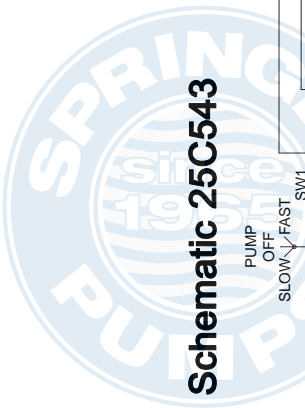

Schematic 25C543

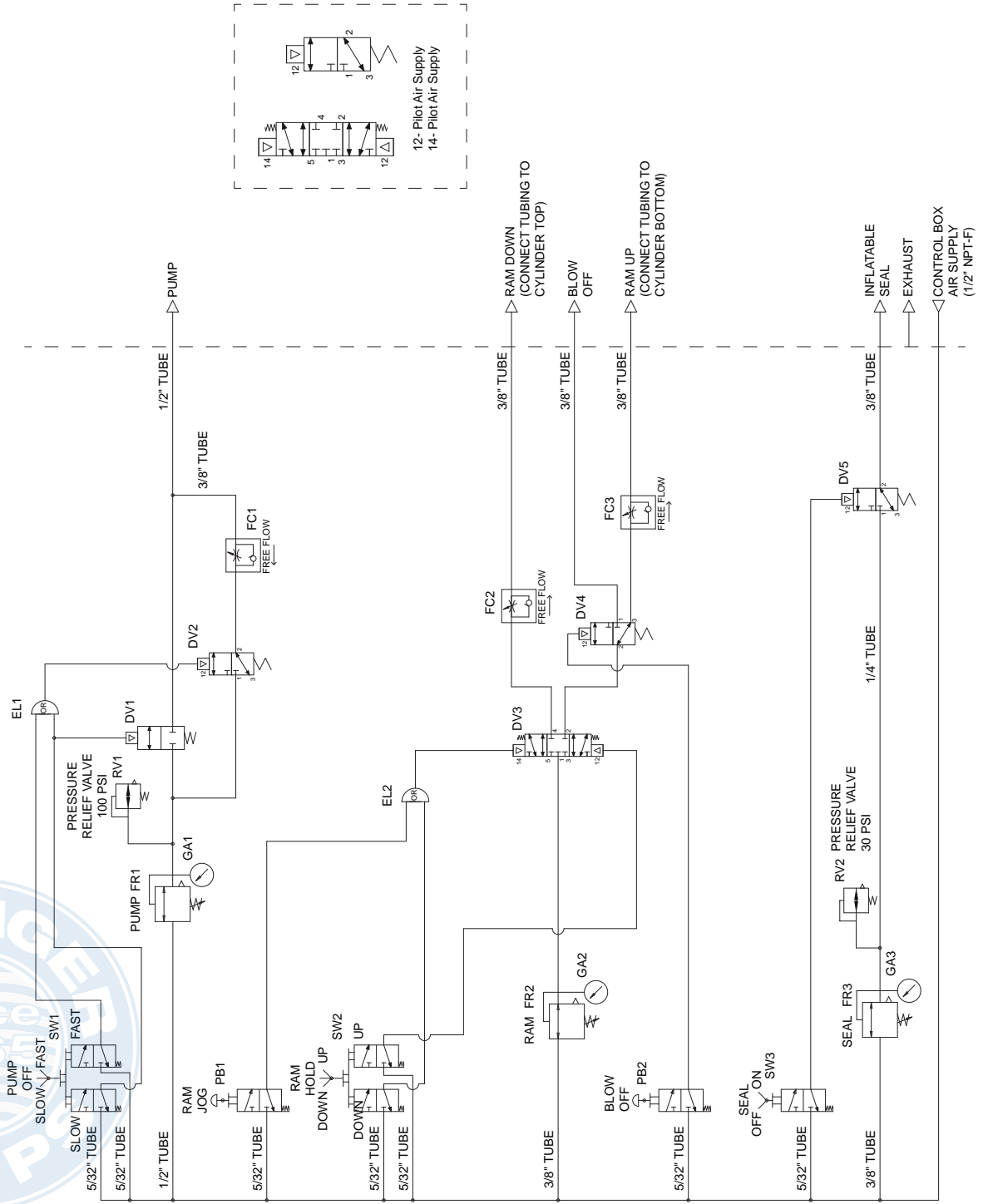

3A6101B

Tel: 866-777-6060
Fax: 866-777-6383

Springer Pumps, LLC

Website: www.springerpumps.com
Int'l: +001 267 404 2910

25C543 Tubing Routing

NOTE: The numbers on this drawing correspond with the tubing from/to entries on the table on the next page.

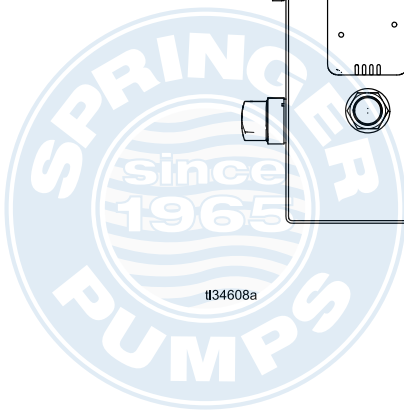
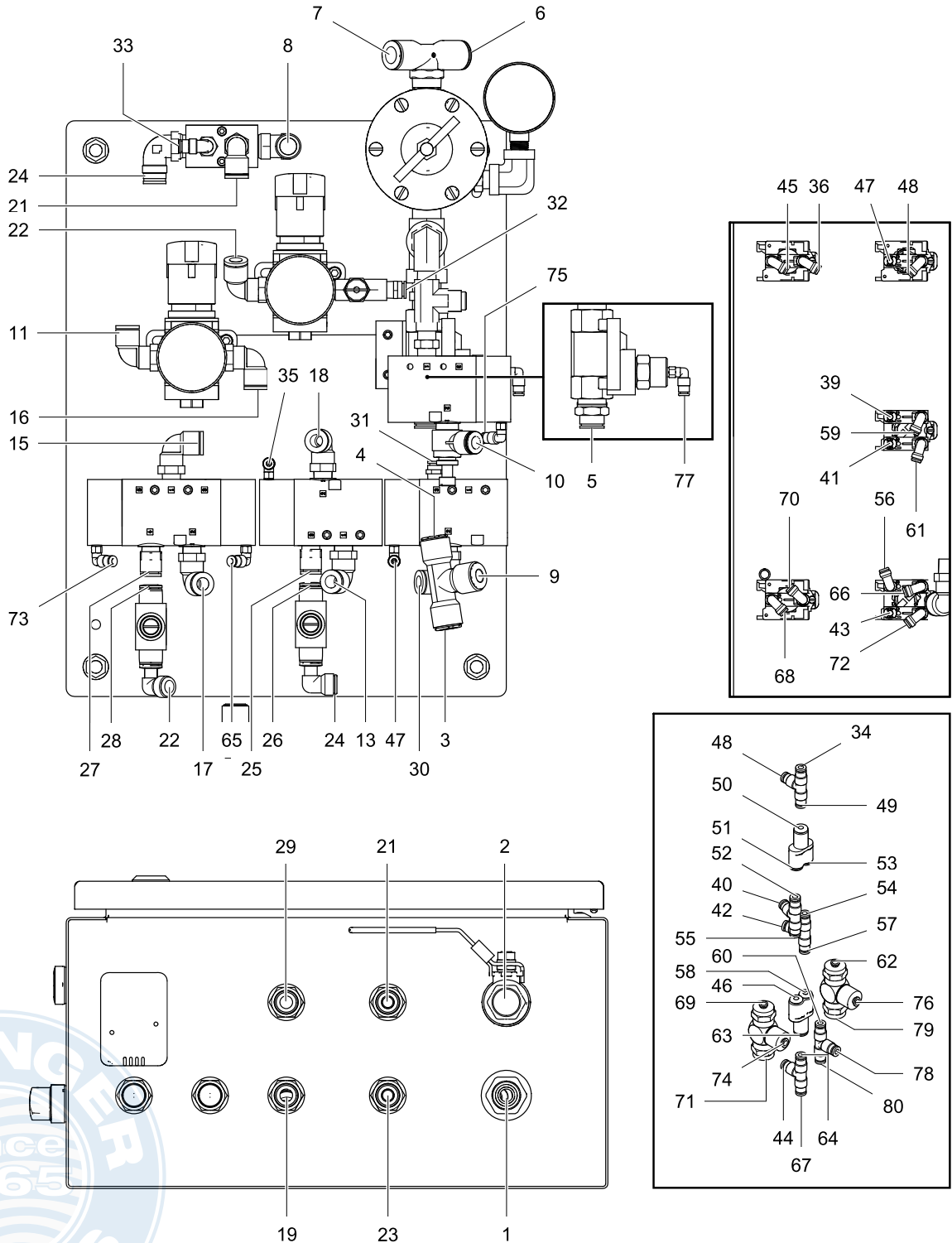

Single Tubes			
TUBE Pt/No.	LENGTH (inches)	FROM	TO
67	7	7	8
67	23	2	6
67	3	1	3
67	5	4	5
68	8	9	10
68	6	11	12
68	4	13	14
68	4	15	16
68	8	17	18
68	6	19	20
68	7	21	22
68	10	23	24
68	1	25	26
68	1	27	28
68	10	29	30
69	9	31	32
70	5	33	34
70	13	35	36
70	2	37	38
70	2	39	40

Single Tubes			
TUBE Pt/No.	LENGTH (inches)	FROM	TO
70	2	41	42
70	2	43	44
70	10	45	46
70	18	47	48
70	2	49	50
70	2	51	52
70	3	53	54
70	5	55	56
70	3	57	58
70	4	59	60
70	3	61	62
70	2	63	64
70	6	65	66
70	5	67	68
70	6	69	70
70	4	71	72
70	5	73	74
70	12	75	76
70	14	77	78
70	4	79	80



3A6101B

Tel: 866-777-6060
Fax: 866-777-6383

Springer Pumps, LLC

Website: www.springerpumps.com
Int'l: +001 267 404 2910

Graco Standard Warranty

Graco warrants all equipment referenced in this document which is manufactured by Graco and bearing its name to be free from defects in material and workmanship on the date of sale to the original purchaser for use. With the exception of any special, extended, or limited warranty published by Graco, Graco will, for a period of twelve months from the date of sale, repair or replace any part of the equipment determined by Graco to be defective. This warranty applies only when the equipment is installed, operated and maintained in accordance with Graco's written recommendations.

This warranty does not cover, and Graco shall not be liable for general wear and tear, or any malfunction, damage or wear caused by faulty installation, misapplication, abrasion, corrosion, inadequate or improper maintenance, negligence, accident, tampering, or substitution of non-Graco component parts. Nor shall Graco be liable for malfunction, damage or wear caused by the incompatibility of Graco equipment with structures, accessories, equipment or materials not supplied by Graco, or the improper design, manufacture, installation, operation or maintenance of structures, accessories, equipment or materials not supplied by Graco.

This warranty is conditioned upon the prepaid return of the equipment claimed to be defective to an authorized Graco distributor for verification of the claimed defect. If the claimed defect is verified, Graco will repair or replace free of charge any defective parts. The equipment will be returned to the original purchaser transportation prepaid. If inspection of the equipment does not disclose any defect in material or workmanship, repairs will be made at a reasonable charge, which charges may include the costs of parts, labor, and transportation.

THIS WARRANTY IS EXCLUSIVE, AND IS IN LIEU OF ANY OTHER WARRANTIES, EXPRESS OR IMPLIED, INCLUDING BUT NOT LIMITED TO WARRANTY OF MERCHANTABILITY OR WARRANTY OF FITNESS FOR A PARTICULAR PURPOSE.

Graco's sole obligation and buyer's sole remedy for any breach of warranty shall be as set forth above. The buyer agrees that no other remedy (including, but not limited to, incidental or consequential damages for lost profits, lost sales, injury to person or property, or any other incidental or consequential loss) shall be available. Any action for breach of warranty must be brought within two (2) years of the date of sale.

GRACO MAKES NO WARRANTY, AND DISCLAIMS ALL IMPLIED WARRANTIES OF MERCHANTABILITY AND FITNESS FOR A PARTICULAR PURPOSE, IN CONNECTION WITH ACCESSORIES, EQUIPMENT, MATERIALS OR COMPONENTS SOLD BUT NOT MANUFACTURED BY GRACO. These items sold, but not manufactured by Graco (such as electric motors, switches, hose, etc.), are subject to the warranty, if any, of their manufacturer. Graco will provide purchaser with reasonable assistance in making any claim for breach of these warranties.

In no event will Graco be liable for indirect, incidental, special or consequential damages resulting from Graco supplying equipment hereunder, or the furnishing, performance, or use of any products or other goods sold hereto, whether due to a breach of contract, breach of warranty, the negligence of Graco, or otherwise.

FOR GRACO CANADA CUSTOMERS

The Parties acknowledge that they have required that the present document, as well as all documents, notices and legal proceedings entered into, given or instituted pursuant hereto or relating directly or indirectly hereto, be drawn up in English. Les parties reconnaissent avoir convenu que la rédaction du présente document sera en Anglais, ainsi que tous documents, avis et procédures judiciaires exécutés, donnés ou intentés, à la suite de ou en rapport, directement ou indirectement, avec les procédures concernées.

Graco Information

For the latest information about Graco products, visit www.graco.com.
For patent information, see www.graco.com/patents.

To place an order, contact your Graco Distributor or call to identify the nearest distributor.

Phone: 612-623-6921 or Toll Free: 1-800-328-0211 Fax: 612-378-3505

All written and visual data contained in this document reflects the latest product information available at the time of publication.
Graco reserves the right to make changes at any time without notice.
Original Instructions. This manual contains English. MM 3A6101

Graco Headquarters: Minneapolis
International Offices: Belgium, China, Japan, Korea

GRACO INC. AND SUBSIDIARIES • P.O. BOX 1441 • MINNEAPOLIS MN 55440-1441 • USA
Copyright 2018, Graco Inc. All Graco manufacturing locations are registered to ISO 9001.

www.graco.com
Revision B, January 2019