

Instructions and Parts



SaniForceTM Sanitary Drum Pumps

3A4586E

EN

For use in sanitary applications to transfer medium to high viscosity fluids. Not approved for use in explosive atmospheres or hazardous locations. For professional use only.

See page 3 for model information, including maximum fluid working pressure.



Important Safety Instructions

Careless pump operation can result in serious injury. Read all warnings and instructions in this manual. Save these instructions.

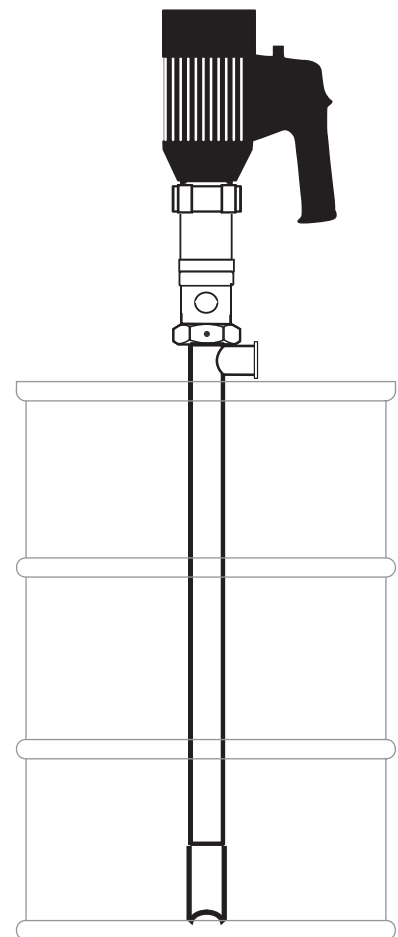

Model 25C420 Shown

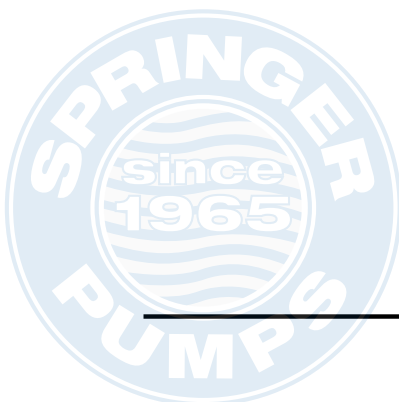



Contents

Models	3	Parts	22
Warnings	4	Complete Pump Models 25C411, 25C412, 25C413, and 25C414	24
Installation	6	Complete Pump Models 25C420, 25C421, 25C780, 25C781	26
Grounding	6	Complete Pump Models 25C416 - 25C419, 25C776 - 25C779	28
Mounting	6	Complete Pump Model 25C422, 25C782	30
Electrical Connections (17N668 Motor)	7	Performance Charts	32
Setup	9	Models 25C411 - 25C419, 25C776 - 25C779 ..	32
Pre-Start Checklist	9	Models 25C420 - 25C421, 25C780 - 25C781 ..	33
Flush Before First Use	9	Model 25C422, 25C782	34
Tighten Connections	9	Dimensions	35
Operation	10	Models 25C411, 25C412, 25C416, 25C417, 25C776, 25C777	35
Initial Configuration (17N668 motor with Graco VFD)	11	Models 25C413, 25C414, 25C418, 25C419, 25C778, 25C779	35
Graco VFD Operation (17N668 motor)	11	Models 25C420, 25C421, 25C780, 25C781 ..	36
Pump Shutdown	12	Models 25C422, 25C782	36
Troubleshooting	13	Technical Data	37
Maintenance	14		
Flushing Procedure	14		
Cleaning Procedure	14		
Models 25C411 - 25C414	15		
Models 25C416 - 25C419, 25C776 - 25C779 ..	17		
Models 25C420, 25C421, 25C422, 25C780, 25C781, 25C782	19		
17N666 and 17N667 Motor Maintenance	21		



Models

System Model	Motor		Lower Unit			Motor Approvals	
	Model	Type	Model	Length	Notes		
Impeller							
25C411	17N666	115 VAC, variable speed †	17N669	39 inches		See ETL label  See ETL label 	
25C413	17N666	115 VAC, variable speed †	17N670	47 inches			
25C412	17N667	230 VAC, Euro plug, variable speed ‡	17N669	39 inches			
25C414	17N667	230 VAC, Euro plug, variable speed ‡	17N670	47 inches			
High Volume							
25C416	17N666	115 VAC, variable speed †	17N671	39 inches			
25C417	17N667	230 VAC, Euro plug, variable speed ‡	17N671	39 inches			
25C418	17N666	115 VAC, variable speed †	17N672	47 inches			
25C419	17N667	230 VAC, Euro plug, variable speed ‡	17N672	47 inches			
High Pressure							
25C776	17N666	115 VAC, variable speed †	17S148	39 inches			
25C777	17N667	230 VAC, Euro plug, variable speed ‡	17S148	39 inches			
25C778	17N666	115 VAC, variable speed †	17S149	47 inches			
25C779	17N667	230 VAC, Euro plug, variable speed ‡	17S149	47 inches			
Progressive Cavity ♦							
25C780	17N666	115 VAC, variable speed †	17S150	39 inches	bag-liner foot		See ETL label
25C420	17N666	115 VAC, variable speed †	17N673	39 inches			
25C781	17N667	230 VAC, Euro plug, variable speed ‡	17S150	39 inches	bag-liner foot	 UL recognized component	
25C421	17N667	230 VAC, Euro plug, variable speed ‡	17N673	39 inches			
25C422*	17N668	190/380 or 230/460 VAC, 3 phase, water washdown	17N674	39 inches			
25C782*	17N668	190/380 or 230/460 VAC, 3 phase, water washdown	17S153	39 inches	bag-liner foot		

* Pump hanger 17P662 included.

† Wired with a North American "Type B" 3-pin plug.

‡ Wired with a European "Type F" 2-pin plug.

♦ Pump elevator 24V310 or 24V311 can be used with these pumps. Pump mounting bracket 24V303 may work for mounting on customer-owned elevators. These are ordered separately.

ETL Label



Type B

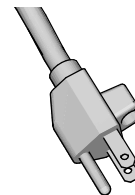



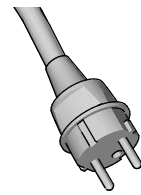







Type F



Warnings

The following warnings are for the setup, use, grounding, maintenance, and repair of this equipment. The exclamation point symbol alerts you to a general warning and the hazard symbols refer to procedure-specific risks. When these symbols appear in the body of this manual, refer back to these Warnings. Product-specific hazard symbols and warnings not covered in this section may appear throughout the body of this manual where applicable.

 <h2 style="margin: 0;">WARNING</h2>	
	<p>PRESSURIZED EQUIPMENT HAZARD</p> <p>Fluid from the equipment, leaks, or ruptured components can splash in the eyes or on skin and cause serious injury.</p> <ul style="list-style-type: none"> • Follow the Pressure Relief Procedure when you stop dispensing and before cleaning, checking, or servicing equipment. • Tighten all fluid connections before operating the equipment. • Check hoses, tubes, and couplings daily. Replace worn or damaged parts immediately.
	<p>MOVING PARTS HAZARD</p> <p>Moving parts can pinch, cut or amputate fingers and other body parts.</p> <ul style="list-style-type: none"> • Keep clear of moving parts. • Do not operate equipment with protective guards or covers removed. • Pressurized equipment can start without warning. Before checking, moving, or servicing equipment, follow the Pressure Relief Procedure and disconnect all power sources.
	<p>FIRE AND EXPLOSION HAZARD</p> <p>Flammable fumes, such as solvent and paint fumes, in work area can ignite or explode. To help prevent fire and explosion:</p> <ul style="list-style-type: none"> • Use equipment only in well ventilated area. • Eliminate all ignition sources; such as pilot lights, cigarettes, portable electric lamps, and plastic drop cloths (potential static arc). • Keep work area free of debris, including solvent, rags and gasoline. • Do not plug or unplug power cords, or turn power or light switches on or off when flammable fumes are present. • Ground all equipment in the work area. See Grounding instructions. • Use only grounded hoses. • Hold gun firmly to side of grounded pail when triggering into pail. • If there is static sparking or you feel a shock, stop operation immediately. Do not use equipment until you identify and correct the problem. • Keep a working fire extinguisher in the work area.

 WARNING	
 	<p>ELECTRIC SHOCK HAZARD</p> <p>This equipment must be grounded. Improper grounding, setup, or usage of the system can cause electric shock.</p> <ul style="list-style-type: none"> • Turn off and disconnect power cord before servicing equipment. • Connect only to grounded electrical outlets. • Use only 3-wire extension cords. • Ensure ground prongs are intact on power and extension cords. • Do not expose to rain. Store indoors. • Do not submerge the motor in liquid. • Never carry the motor by the power cord.
 	<p>EQUIPMENT MISUSE HAZARD</p> <p>Misuse can cause death or serious injury.</p> <ul style="list-style-type: none"> • Do not operate the unit when fatigued or under the influence of drugs or alcohol. • Do not exceed the maximum working pressure or temperature rating of the lowest rated system component. See Technical Data in all equipment manuals. • Use fluids and solvents that are compatible with equipment wetted parts. See Technical Data in all equipment manuals. Read fluid and solvent manufacturer's warnings. For complete information about your material, request SDS from distributor or retailer. • Do not leave the work area while equipment is energized or under pressure. • Turn off all equipment and follow the Pressure Relief Procedure when equipment is not in use. • Check equipment daily. Repair or replace worn or damaged parts immediately with genuine manufacturer's replacement parts only. • Do not alter or modify equipment. • Make sure all equipment is rated and approved for the environment in which you are using it. • Use equipment only for its intended purpose. Call your distributor for information. • Route hoses and cables away from traffic areas, sharp edges, moving parts, and hot surfaces. • Do not kink or over bend hoses or use hoses to pull equipment. • Keep children and animals away from work area. • Comply with all applicable safety regulations.
	<p>BURN HAZARD</p> <p>Equipment surfaces and fluid that is heated can become very hot during operation. To avoid severe burns:</p> <ul style="list-style-type: none"> • Do not touch hot fluid or equipment.
	<p>PERSONAL PROTECTIVE EQUIPMENT</p> <p>You must wear appropriate protective equipment when operating, servicing, or when in the operating area of the equipment to help protect you from serious injury, including eye injury, hearing loss, inhalation of toxic fumes, and burns. This equipment includes but is not limited to:</p> <ul style="list-style-type: none"> • Protective eyewear, and hearing protection. • Respirators, protective clothing, and gloves as recommended by the fluid and solvent manufacturer.

Installation

Grounding



The equipment must be grounded to reduce the risk of static sparking and electric shock. Electric or static sparking can cause fumes to ignite or explode. Improper grounding can cause electric shock. Grounding provides an escape wire for the electric current.

Grounding is an electrical connection between a metal vessel, pump, or motor and a true earth ground.

Motor: Electrical cords must be connected to outlets with electrical ground.

Pump: Ensure that the ground screw provided with the pump is connected to a true earth ground. Insert one end of a 14 AWG minimum ground wire behind the ground screw and tighten the screw securely. Connect the clamp end of the grounding wire to a true earth ground. A ground wire and clamp, Part 238909, is available from your Graco distributor.

Fluid hoses: use only electrically conductive hoses with a maximum of 500 ft. (150 m) combined hose length to ensure grounding continuity. Check electrical resistance of hoses. If total resistance to ground exceeds 25 megohms, replace hose immediately.

Material supply container: follow local code.

Container(s) that receive material: follow local code.

To maintain grounding continuity when flushing or relieving pressure: hold metal part of the dispense valve firmly to the side of a grounded metal pail, then trigger the valve.

Mounting



To avoid injury from a falling pump, model 25C422 or 25C782, check the connections on the motor hanger (302) before using the motor hanger to lift the pump.

1. Remove the pump and motor from packaging.
2. Inspect all contents for damage.
3. Install the motor with pump lower:
 - a. On pumps using the 17N668 motor, hang the pump using the included motor hanger (302) using adequate hardware, following local code. Torque the motor hanger to 30-36 ft-lb (41-49 N-m).
 - b. On pumps using the 17N666 or 17N667 motor, attach motor to pump by tightening the motor nut on the pump.

NOTICE

To avoid damaging the pump, do not overtighten the mounting hardware.

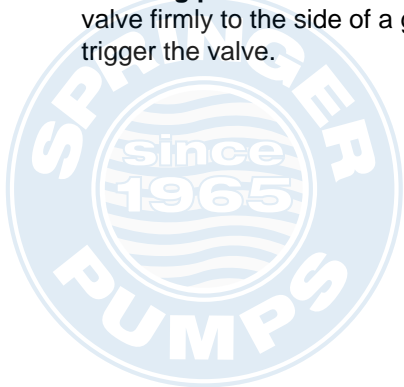

Electrical Connections (17N668 Motor)

Wire Connections at the Motor

				
To avoid injury from fire, explosion, or electric shock, all electrical wiring must be done by a qualified electrician and comply with all local codes and regulations.				

NOTE: Graco recommends the use of a motor soft starter or a VFD in the electrical circuit for all installations. In all cases, make sure all products are installed in accordance with local codes and regulations.

1. Remove 4 bolts to open the motor's electrical box.
2. Internal Wiring:
 - a. **For 460V Motors:** The motor typically comes wired for 460 V. If this is the voltage you want, the existing wiring can remain as it is.

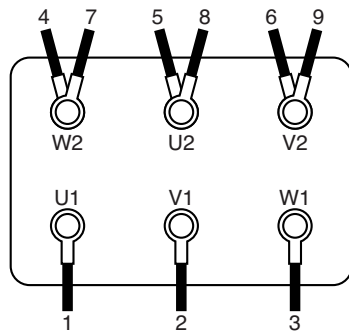



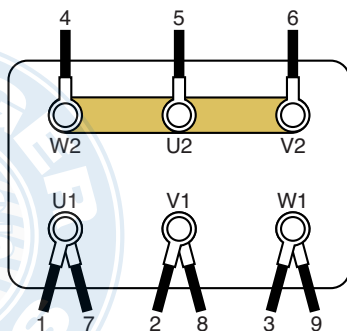

- b. **For 230V Motors:** Move the 7, 8, and 9 wires as shown. Bridge W2, U2, and V2 as shown.



3. Install wiring system with proper liquid-tight connections in one of the ports at the bottom of the motor box.
4. Connect the ground wire to the ground screw. Torque the M5 stud to 17.7 in-lb (2.0 N-m).
5. Connect power wires L1, L2 and L3 to line terminals U1, V1, and W1.
6. Torque terminals to 14.2 in-lb (1.6 N-m). Do not overtorque.
7. Close the motor electrical box. Torque the screws to 20 in-lb (2.3 N-m).

Wire Connections at the Variable Frequency Drive (VFD)

				
To avoid injury from fire, explosion, or electric shock, all electrical wiring must be done by a qualified electrician and comply with all local codes and regulations.				
<ul style="list-style-type: none"> • Disconnect power before servicing. • Wait 5 minutes for capacitor discharge before opening. 				

NOTE: For variable speed control, the motor must be wired to a VFD. Follow the instruction in the VFD manufacturer's manual.

If you purchased an optional Graco VFD, install wiring at the VFD as follows:

1. Connect the wires to the motor. See **Wire Connections at the Motor**.
2. Open the VFD's electrical box.
3. Install the wiring system with proper liquid-tight connections for incoming supply power and for outgoing motor power.
4. Connect the ground wires for the VFD and for the motor to the ground screw.
5. Connect the wires from the motor terminals to the matching terminals in the VFD box, as shown.

Installation

6. Connect the power supply wires to the power terminals in the VFD box. See the following table and figures, as applicable to your system.
7. Close the VFD electrical box.
8. Perform the VFD configuration.

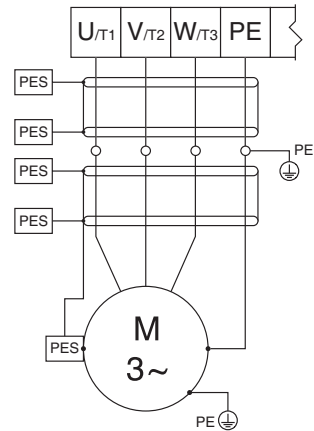

VFD Part No.	HP	Nominal Input Voltage	Input Voltage Range	Nominal Output Voltage†	See Figure
16K909	1.5	120 Vac, 1 phase	90-132 Vac	240 Vac, 3 phase	FIG. 1
16K909	1.5	240 Vac, 1 phase	170-264 Vac	240 Vac, 3 phase	FIG. 2
16K910	1.5	208-240 Vac, 1 phase	170-264 Vac	208-240 Vac, 3 phase	FIG. 3
16K910	1.5	208-240 Vac, 3 phase	170-264 Vac	208-240 Vac, 3 phase	FIG. 4

† Output voltage is dependent on input voltage.

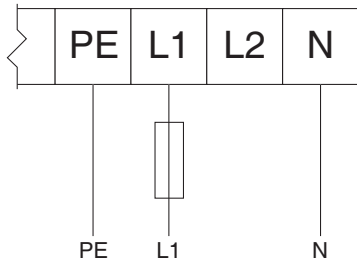

FIG. 1 120 Vac 1 Phase Input/240 Vac 3 Phase Output

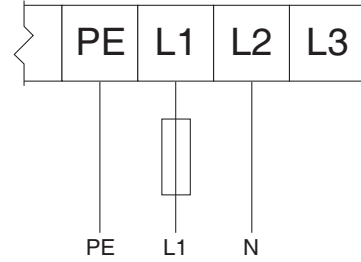

FIG. 3 208-240 Vac 1 Phase Input/208-240 Vac 3 Phase Output

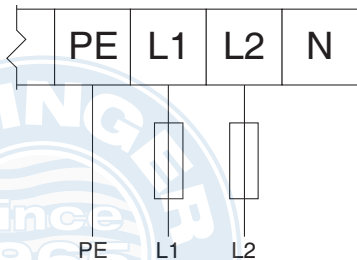

FIG. 2 240 Vac 1 Phase Input/240 Vac 3 Phase Output

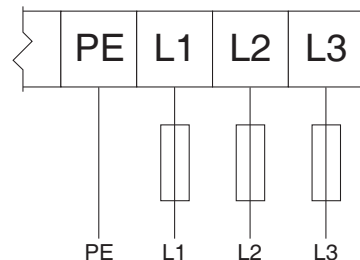

FIG. 4 190, 208-240 Vac 3 Phase Input/190, 208-240 Vac 3 Phase Output

Setup

Accessories are available from Graco. Make certain all accessories are sized and pressure-rated to meet your system requirements.

- Verify that the motor voltage corresponds to proper electrical supply. Before plugging motor into power supply, make sure the motor switch is in the OFF position.
- Before operation, confirm all pump connections are properly tightened.
- Before starting the pump, confirm the discharge hose is securely fastened to the receiving vessel in order to prevent splashing.

Pre-Start Checklist

Verify each of the following items before starting the pump.

- **DEBRIS:** Ensure that the fluid supply is free of dirt, debris, and any contaminants.
- **HOSE MATERIAL:** Check that the hose material is compatible with the fluid being pumped. Consult your Graco distributor for available hose materials.
- **FASTENERS:** Check that all fasteners are properly tightened.
- **LEAKS:** Check the connections on the fluid outlet to be sure there are no leaks.

Flush Before First Use





The sanitary pump was assembled using sanitary lubricant on moving parts and was tested in water. Flush the pump thoroughly with an appropriate cleaning solution, and disassemble and sanitize the parts before using the pump. See **Flushing Procedure**, page 14. Check national, state, and local codes for specific limitations.

Tighten Connections

Before each use, check all hoses for wear or damage. Replace as necessary. Check that all connections are tight and leak-free.



Operation

				
<ul style="list-style-type: none">• Moving parts can pinch, cut or amputate fingers and other body parts. Keep your hands and fingers away from the mechanical seal viewing window on models 25C422 or 25C782 during operation and whenever the pump is connected to a power source. Disconnect power before moving.• Do not use these pumps for the transfer of flammable or combustible products or in an environment where flammable or combustible fumes are present.• Do not clean or flush the pump with flammable or combustible fluids.• Progressive cavity pumps are positive displacement pumps and should never be operated against shut-off elements such as nozzles, valves, etc. Failure to comply may result in excessive pressure build resulting in serious injury and pump damage.				

use a hose that is rated 4x the pump discharge pressure.

- b. Fasten the hose to the hose barb with a suitable hose clamp that exceeds the pump discharge pressure. A hose barb fitting kit, part 25C502, is available from your Graco distributor.
5. Variable speed pumps should be started at approximately half speed according to the dial settings. Turn the motor to the ON position. Throttle flow to desired output pressure by varying the potentiometer (motors 17N666 and 17N667) or VFD frequency, if applicable on motor 17N668.
6. After use, flush and clean the pump. Then store the pump vertically.

NOTICE
<ul style="list-style-type: none">• Never allow the pump to run dry of fluid. A dry pump will possibly damage itself.• Progressive cavity pumps 25C420, 25C421, 25C780, and 25C781 are recommended for intermittent duty use only to prevent premature motor wear. (i.e., 30 minute intervals with a 10 minute cooling off period). For continuous duty applications, Graco recommends using models 25C422 or 25C782.

1. Use closed top drum or other cover to prevent possible contamination.
2. Once the pump is fully cleaned, assembled, and all connections are securely fastened, insert the pump into the drum or tank.
3. It is recommended to attach a suitable hose or pipe to the pump discharge.
4. If you opt to use a hose:
 - a. Ensure that the hose meets the pump discharge pressure requirements. It is recommended to

Initial Configuration (17N668 motor with Graco VFD)

For initial setup, review at least the following menus to configure the system to suit your particular needs. See your VFD manual for detailed information about each menu option and about default settings.

1. VFD Parameter P103 controls the maximum frequency (the top end of manual speed) of running your pump. This setting is NOT your operating frequency. It is the maximum limit of operating frequency.
2. VFD Parameter P108 controls motor overload. Set so that the VFD cannot supply more current to the motor than it can handle. The formula for the set value is:

$$X = \text{Motor current rating} \times 100 / \text{VFD output current rating}$$
3. VFD Parameter P171 controls the absolute current limit. It is set to allow for momentary spikes in current above the limit set in P108. A spike occurs, for example, when the roller passes over the double hose section. This parameter is usually set for 2 to 3 times the value on menu P108, which was calculated in the previous step.
4. VFD Parameter P112 controls the direction of motor rotation. See **Reverse Motor Direction**, page 12.
5. VFD Parameter P104 (optional) controls the rate at which the motor will ramp up to the set speed.
6. VFD Parameter P166 (optional) allows for adjustment to the noise that the motor creates. Each setting changes the tone.

Graco VFD Operation (17N668 motor)

VFD Control Panel

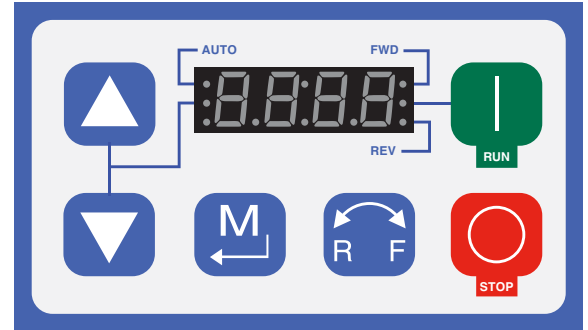

NOTE: For complete information about the VFD, see the manufacturer's instructions supplied with the VFD.

- The control panel display shows the status of the motor. It also shows the direction of motor rotation: FWD (forward) or REV (reverse).
- The green RUN key starts the motor.
- The red STOP key stops the motor.
- Use the arrow keys to speed up or slow down the motor.
- The blue R/F key changes the motor rotation (see **Reverse Motor Direction**, page 12).
- The blue M key accesses the VFD menu. See the manufacturer's instructions for menu descriptions and information.

If the M key is pressed, use the arrow keys to scroll through the VFD menu.

Factory Settings

VFD settings are preset at the factory for most applications. See **Initial Configuration (17N668 motor with Graco VFD)**, page 11, to change the default settings as needed to suit your needs.



Reverse Motor Direction

NOTE: VFD Parameter P112 controls the direction of motor rotation. The VFD is shipped with the rotation set to forward as a default.

1. Verify which direction the pump is rotating.
2. Press the M key to access the VFD menu.
3. Scroll to **P112**, using the arrow keys.
4. Press the M key again.
5. **00** will display on the screen. Use the arrow keys to set the display to **01**. This allows both forward and reverse rotation.
6. Press the M key to enter the setting. The screen will display STOP or the last frequency setting.

NOTE: To use this feature when operating the pump, press the R/F key, then the M key. The drive will slow and the motor will reverse direction. Press the RUN key and check that the roller is moving in the opposite direction.

Adjust the Speed

Use the arrow keys on the VFD control panel to increase or decrease the motor speed.

Pump Shutdown

The output pressure will drop as soon as the motor is turned off. Any low viscosity fluid in the inlet tube of an impeller pump will fall to the level of the fluid of the source vessel. Higher viscosity fluids in an impeller model or any progressive cavity pump will remain at the level at the time of shutdown.

Pump shutdown is possible using the ON/OFF switch on the motor.



Troubleshooting

NOTICE

The variable speed control should not be used as an ON/OFF control. It will stop the motor from operating, but does not turn off the motor.



Check all possible remedies in the Troubleshooting Chart before disassembling the pump.

Problem	Cause	Solution
Pump fails to operate.	Exhausted fluid supply.	Refill fluid supply.
	Damaged motor.	Replace motor.
	No power to motor.	Ensure motor is plugged in to correct power outlet.
Pump operates, but output low.	Cavitation due to excessive pump speed.	Reduce pump speed.
	Exhausted fluid supply.	Refill fluid supply.
	Obstructed fluid line	Clear fluid line.
Erratic or accelerated operation.	Exhausted fluid supply.	Refill fluid supply.
Rattling sound	Loose motor nut.	Tighten motor nut.



Maintenance

Flushing Procedure



NOTE:

- Flush before fluid can dry in the equipment, at the end of the day, before storing, and before repairing equipment.
 - Flush at the lowest pressure possible. Check connectors for leaks and tighten as necessary.
 - Flush with an appropriate cleaning solution.
1. Remove the pump from the fluid container.
 2. Place siphon tube in grounded metal pail containing an appropriate cleaning solution.
 3. Set pump to lowest possible fluid pressure, and start pump.
 4. Run the pump long enough to thoroughly clean the pump and hoses.

Cleaning Procedure

NOTE: The following instructions are a basic procedure for cleaning a sanitary pump.

- **Be sure** to follow your national and state sanitary standard codes and local regulations.
- Use appropriate cleaning and disinfecting agents, at intervals appropriate for product processed.
- Follow cleaning product manufacturer's instructions.

NOTE: The pump **must be disassembled** to clean it thoroughly.

1. Remove the pump from the fluid container.
2. Flush the system thoroughly with an appropriate cleaning solution. See **Flushing Procedure**, page 14.
3. Remove the fluid hoses and fittings from the pump.



4. Disassemble the fluid pump and accessories. See **Models 25C411 - 25C414**, page 15, **Models 25C416 - 25C419, 25C776 - 25C779**, page 17 or **Models 25C416 - 25C419, 25C776 - 25C779**, page 19.
5. Wash all pump parts with an appropriate cleaning solution at the cleaning product manufacturer's recommended temperature and concentration.
6. Rinse all pump parts again with water and allow them to dry.
7. Inspect all pump parts and reclean if needed.

NOTE: Any damaged rubber parts **must** be replaced as they could harbor microorganisms that can contaminate the fluid.

8. Immerse all pump parts in an appropriate sanitizer before assembly. Take the pump parts out of the sanitizer one-by-one as needed.
9. Lubricate the threaded parts and o-rings with appropriate waterproof sanitary lubricant.
10. Circulate the sanitizing solution through the pump and the system prior to use.

Models 25C411 - 25C414

Uninstall the Pump

				
<p>Moving parts can pinch, cut or amputate fingers and other body parts. Keep your hands and fingers away from the pump inlet during operation and whenever the pump is connected to a power source. Disconnect power before moving.</p>				

1. Turn off the motor.
2. Disconnect the motor from the power source and detach the ground wire from the lower unit.
3. Remove the fluid hose from the pump.
4. Remove the pump from container.
5. Carry the pump to the bench for service.

Disassemble the Pump

NOTE: If removal of any part requires use of a tool for gripping, use only non-marring tools.

1. Remove motor by unthreading the motor nut (2).
2. Remove the foot (19).
NOTE: This part is reverse threaded. While facing the bottom of the foot, rotate the foot clockwise to remove.
3. Grasp the coupling (4) with one hand and the impeller (18) with the other hand. Unscrew the coupling or impeller:
NOTE: If the coupling unscrews, capture the two bearings (5), bearing spacer (6) and u-cup (7) for re-use when removing the drive shaft from the tube.
4. Using the remaining item still attached to the drive shaft, pull the drive shaft out of the tube.
NOTE: The guide sleeve (9) may also come out when removing the drive shaft. If it does, remove it from the tube and drive shaft. If it does not come out now, it will be removed later.
5. Unscrew the coupling or impeller from the drive shaft. If it is the coupling, retain the 2 bearings (5), bearing spacer (6) and u-cup (7) for re-use.

6. If the guide sleeve (9) did not come out with the drive shaft, remove it now. It must be removed from the motor end of the tube because of the flare on the end of the guide sleeve.
NOTE: If necessary, use a non-marring object which is at least 12 inches long inserted from the foot end of the inner tube to push the guide sleeve out far enough to present a graspable surface.
7. Remove the pump housing (16).
NOTE: This part is reverse threaded. While facing the foot end of the tube, rotate the pump housing clockwise to remove.
8. Remove the bushing (17) from the pump housing.
NOTE: The exposed end of the bushing is flared. If necessary, push against the inside end of the bushing to expose a graspable surface.
9. Using an o-ring tool, remove the two o-rings (15) from the inner tube.
10. Remove the flange (10).
NOTE: This part is reverse threaded. While facing from the motor end of the tube, rotate the flange clockwise to remove.
11. Using a flat-blade screwdriver, remove the snap ring (3) from the motor nut (2) and remove both from the flange (10).
12. Clean and inspect all components. Replace any damaged components.

Reassemble After Cleaning

NOTE: Any damaged parts **must** be replaced as they could harbor microorganisms that can contaminate the fluid.



NOTE: Lubricate the o-rings and threaded fittings with appropriate waterproof sanitary lubricant during assembly.

1. Install the two O-rings (15) onto the inner tube.
2. Install non-flared end of the guide sleeve (9) into the inner tube of tube (14) from the motor end. Push down into the inner tube until the flared end is against the end of the inner tube.
3. At the foot end of tube (14) align the inner tube with the large opening of the pump housing. Turning counter-clockwise, install the pump housing. Tighten hand tight.
4. At pump housing (16) insert the non-flared end of bushing (17) and press the bushing into the pump housing until the flared end of the bushing is against the center portion.
5. At the motor end of the tube (14) place the snap ring (3) on the tube for use in the next step. Install the connection flange onto the tube. Tighten hand tight.
6. Install the nut (2) and snap ring (3) on the connection flange (10).
7. On the drive shaft, locate the end with stepped diameters. With this end of the drive shaft facing to the right, install the u-cup (7) with the opening facing right, a bearing (5), spacer (6), bearing (5) and coupling (4). Tighten finger tight.
8. Insert the impeller end of the drive shaft through the connection flange (10) until the bearings are seated in the connection flange.
NOTE: If binding occurs during insertion, rotating the drive shaft should help.
9. At the foot end of the tube, attach the impeller onto the drive shaft. Hold the coupling on one end of the drive shaft and the impeller on the other. Tighten both finger tight.
10. Facing the foot end of the tube (14), install the foot (19) on the tube. Tighten finger tight by screwing the foot counter-clockwise.
11. Attach the motor to the lower unit by tightening motor nut (2) hand tight.
12. When installing pump into container, attach the ground wire to the lower unit as specified in **Grounding** on page 6.



Models 25C416 - 25C419, 25C776 - 25C779

Uninstall the Pump

				
<p>Moving parts can pinch, cut or amputate fingers and other body parts. Keep your hands and fingers away from the pump inlet during operation and whenever the pump is connected to a power source. Disconnect power before moving.</p>				

1. Turn off the motor.
2. Disconnect the motor from the power source and detach the ground wire from the lower unit.
3. Remove the fluid hose from the pump.
4. Remove the pump from container.
5. Carry the pump to the bench for service.

Disassemble the Pump

NOTE: If removal of any part requires use of a tool for gripping, use only non-marring tools.

1. Remove motor by unthreading the motor nut (110).
2. Using a flat-blade screwdriver, remove the snap ring (111) from the motor nut (110) and remove both from the inner tube (103) flange area.
3. Loosen the tri-clamp connector (109).
4. Pull the inner tube assembly (103) out of the outer tube (101).
5. Grasp the impeller (108) with one hand and the motor coupling (112) with the other hand. Unscrew the motor coupling or impeller from the drive shaft (104).
 - If the motor coupling unscrews, retain the two bearings (107), bearing spacer (106) and seal (105) for re-use.
 - If the impeller unscrews, retain the o-ring (116) for re-use.
6. Remove the drive shaft (104).
7. Remove The guide sleeve (114) from the drive shaft (104) or out of the inner tube assembly (103).

8. Remove the remaining attached items on the impeller end, or drive end, of the drive shaft. Retain all parts for re-use.
9. Remove o-ring (117), spacer (115), and bushing (113) from the inner tube (103).
10. Clean and inspect all components. Replace any damaged components.

Reassemble After Cleaning



NOTE: Any damaged parts **must** be replaced as they could harbor microorganisms that can contaminate the fluid.

NOTE: Lubricate the o-rings and threaded fittings with appropriate waterproof sanitary lubricant during assembly.

1. Install the bushing (113) and wing spacer (115) on the inner tube (103). Ensure that the wing spacer flat is properly aligned with the inner tube and install the o-ring (117).
2. Install non-flared end of the guide sleeve (114) into the inner tube (103) from the motor end. Push down into the inner tube until the flared end is against the end of the inner tube.
3. On the end of the drive shaft (104) without the o-ring groove, install the seal (105), bearing (107), bearing spacer (106), bearing (107), and motor coupling (112).
4. Insert the drive shaft assembly into the inner tube (103) guide sleeve (114).
5. At the exposed end of the drive shaft, install the o-ring (116) and the impeller (108). Grasp the motor coupling and impeller and hand tighten.
6. At the motor end of the inner tube (103) place the snap ring (111) on the tube for use in the next step.
7. Install the nut (110) and snap ring (111) on the inner tube (103) connection flange.
8. Install the seal (102) onto the inner tube (103) and insert the inner tube assembly into the outer tube (101). Align the drainage slot in the wing spacer with the drainage slot in the outer tube. Install coupling (109).
9. Attach the motor to the lower unit by tightening motor nut (110) hand tight.
10. When installing pump into container, attach the ground wire to the lower unit as specified in **Grounding** on page 6.



Models 25C420, 25C421, 25C422, 25C780, 25C781, 25C782

				
<ul style="list-style-type: none"> • Moving parts can pinch, cut or amputate fingers and other body parts. Keep your hands and fingers away from the pump inlet during operation and whenever the pump is connected to a power source. • Keep hands away from mechanical seal viewing window on models 25C422 or 25C782. • The motor on some models is heavy. A single person should not attempt to move or perform maintenance on these models unless precautions are taken to prevent injury. Do not attempt to disconnect a heavy motor while the pump is in a vertical position. 				

Uninstall the Pump

1. Turn off the motor.
2. Disconnect the motor from the power source and detach the ground wire from the lower unit.
3. Remove the fluid hose from the pump.
4. Remove the pump from container.
5. Transport the pump to the bench for service.

Disassemble the Pump

NOTE: If removal of any part requires use of a tool for gripping, use only non-marring tools.

1. Remove the motor:
 - a. On models 25C420, 25C421, 25C780, or 25C781, remove the motor nut (203).
 - b. On model 25C422 or 25C782, position the pump on a flat surface with the motor lying on its side. Remove the four bolts (305a), motor (301), motor hanger (302), and motor mount flange (305).

NOTE: Part references are for model 25C420. The equivalent parts of other models can be used instead.

2. Insert a rigid rod, such as a screwdriver or long hex wrench, into the inspection hole of the gear reducer (205) and position through the center shaft as a lever to prevent the gear reducer from rotating while loosening the hex nut in the next step.
3. Using a 4mm hex wrench, loosen the setscrew (213) and then the hex nut attaching the tube (318) to the gear reducer (205).
4. Remove the stator tube (220 or 221) from the outer tube (217).

NOTE: This part is reverse threaded. While facing the bottom of the stator tube, rotate the stator tube clockwise to remove.
5. Grasp the stator tube (220 or 221) and push the ring (218) and stator (219) toward the threaded end of the stator tube and remove them.

NOTE: The stator has a cutout that aligns with a tab inside the stator tube which keeps it from rotating during operation.
6. Remove the outer tube (217) and gasket (212) to expose the internal drive shaft and other internal components.
7. Viewing through the inspection hole on the gear reducer, rotate the drive shaft so that the hole in the gear reducer drive shaft can be accessed. Insert a rigid rod through the inspection hole and the hole on the gear reducer drive shaft. This will allow the drive shaft to remain stationary while loosening the drive shaft (209) and items attached to the drive shaft.
8. Remove conical spring (207f), washer, lower o-ring, lower seal, upper seal, upper o-ring, and mechanical seal bushing.
9. Clean and inspect all components. Replace any damaged components.

Reassemble After Cleaning

NOTE: Any damaged parts **must** be replaced as they could harbor microorganisms that can contaminate the fluid.

NOTE: Lubricate the o-rings and threaded fittings with appropriate waterproof sanitary lubricant during assembly.

1. Replace damaged seals or o-rings, as necessary. Use food grade lubricant on o-rings.
2. Reinstall mechanical seal bushing (206) into gear reducer (205).
3. Replace upper o-ring (207a), upper seal (207b), lower seal (207c), noting orientation between both seals, lower o-ring (207d), washer (207e), spring (207f) ensuring hook in spring lines up with lower seal housing hole, washer (207e), and gasket (208).
4. Install the female end of the drive shaft (209) into the gear reducer (205), use a rigid rod through the gear reducer observation hole, and tighten the drive shaft hand tight,
5. Install the gasket (212) and outer tube (217) over the drive shaft assembly.
6. When the gasket (212) and the flange of the outer tube (217) meet the bushing (206), the internal drive shaft assembly is properly inserted and the outer tube hex nut can be tightened. Use a large wrench to tighten the hex nut. Tighten the set screw (213).
7. Install the gasket (210) to the male end of the drive shaft before threading the rotor. Tighten hand tight.

NOTE: Food grade lubricant may be used on the stator to aid insertion into the stator tube.

8. While aligning the alignment tab on the stator tube (220 or 221) and the recess on the stator (219), insert the stator into the threaded end of the stator tube.
9. Install the ring (218) and stator tube onto the outer tube (217). Tighten hand-tight.
NOTE: The threads are reverse direction. Tighten by rotating the stator tube in a counter-clockwise direction.
10. Attach the motor:

- a. For 25C420, 25C421, 25C780, or 25C781 pumps, position the motor over the coupler (202) and tighten the nut (203) hand tight.

NOTE: In the next step, attach the motor for the 25C422 or 25C782 while it is resting on a horizontal surface. Do not attempt to assemble in a vertical orientation.

- b. For 25C422 or 25C782 pump, align the coupler, motor, motor hanger, and motor mount flange. Use two longer bolts to loosely attach the motor hanger and motor mount flange to two holes on the motor. Using the four shorter bolts, loosely attach the motor mount flange to the motor. After all bolts are inserted, tighten using a crossing pattern until all bolts are tight. Torque to 30-36 ft-lb (41-49 N-m).

11. When installing pump into container, attach the ground wire to the lower unit as specified in **Grounding** on page 6.

17N666 and 17N667 Motor Maintenance

Prior to performing any maintenance:

- Turn motor off using the ON/OFF switch.
- Unplug the power cord from the power outlet.
- Remove motor from pump.

Brush Replacement

1. Remove four motor cover screws (401) and lift the cover (402) off of the motor.
2. The fan (403) is pressed onto the armature shaft; to remove the fan, insert two flat screwdrivers from opposite sides under the fan and gently twist the screwdrivers uniformly to pry the fan upwards and off the shaft.
3. Remove the bearing cover (404), being careful to retain the wave washer (405) that rests between the armature bearing (406) and bearing cover (404).
4. The two motor brushes are each held down by a Phillips-head screw and a hold-down tab. Loosen each screw approximately one-turn, rotate the tab, and pull up on the brush assembly (408) to remove.
5. Replace both brushes, ensuring the side brush body tabs are aligned with the brush holder (407). Realign the hold-down tabs and gently tighten screws to retain the brushes.
6. Reinstall the wave washer (405) and bearing cover (404) prior to gently pressing the fan (403) onto the armature shaft (414). A groove will prevent the fan from being pressed onto the shaft too far.
7. Align the motor cover with the motor housing and install and tighten the motor cover screws.

Armature Replacement

1. Remove four motor cover screws (401) and lift the cover (402) off of the motor.
2. The fan (403) is pressed onto the armature shaft; to remove the fan, insert two flat screwdrivers from opposite sides under the fan and gently twist the screwdrivers uniformly to pry the fan upwards and off the shaft.
3. Remove the bearing cover (404), being careful to retain the wave washer (405) that rests between the armature bearing (406) and bearing cover (404).

4. The two motor brushes are each held down by a Phillips-head screw and a hold-down tab. Loosen each screw approximately one-turn, rotate the tab, and pull up on the brush assembly (408) to remove.
5. Remove the brush holder (407) by removing the two nuts (8mm deep socket) and washers below the stator contact tabs.
6. Remove the four screws (412) in the lower housing and separate the motor housing from the lower housing and armature assembly.
7. Remove the motor coupling (419) by lightly holding the motor coupling with a pair of long nosed pliers and loosening the armature shaft.
8. The armature shaft is lightly press-fit into the lower housing. Gently tap the armature shaft from the motor coupling end to remove the shaft.
9. Using the new armature, assemble in reverse order.

Power Cord and EMI Filter Replacement

Remove the five switch cover screws (435) to access the power cord (432) and EMI filter (428). Replace as necessary.

ON/OFF switch Replacement

Remove the five switch cover screws (435) and the four switch housing screws (425). Replace the ON/OFF switch (426).

Potentiometer Replacement

Remove the four switch housing screws (425). The potentiometer dial cover is removed by pulling upwards, giving access to a nut; loosen and remove the nut being careful to retain the washers. Remove the potentiometer (422) housing from the motor side of the switch housing.

Parts

Motors 17N666 and 17N667 (Ref 400)

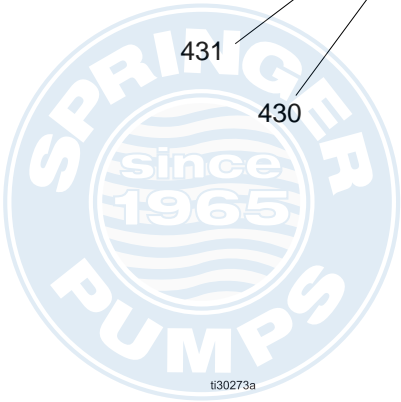
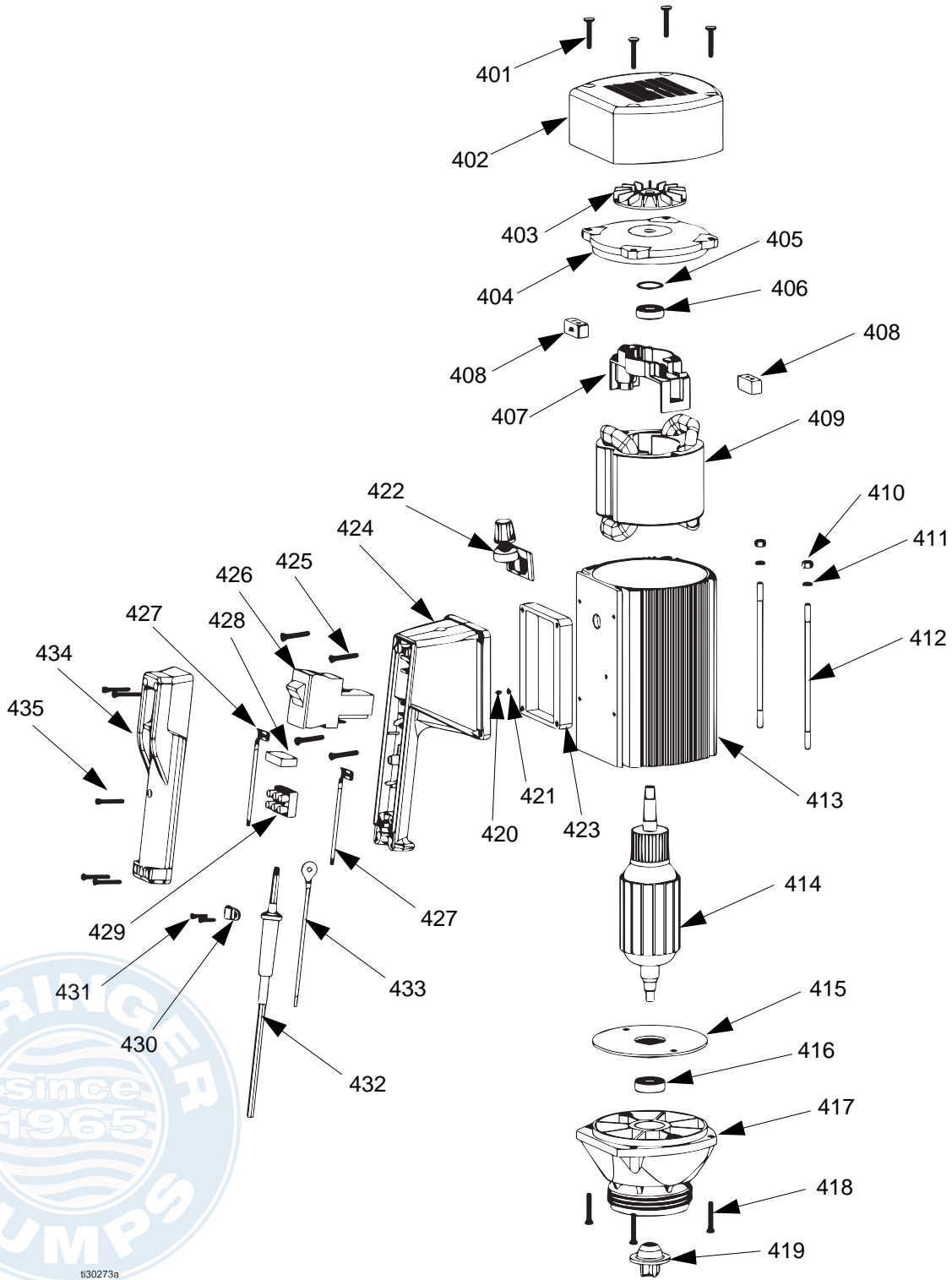

Motors 17N666 and 17N667 (Ref 400)

Ref.	Part	Description	Qty.
401	---	SCREW, M5 x 45mm	4
402	17P967	COVER, motor	1
403	17P968	FAN	1
404	17P969	COVER, bearing	1
405	17P970	WASHER, wave	1
406	17P971	BEARING, upper	1
407	17P972	RETAINER, motor brushes	1
408†	---	BRUSH, motor	2
409		STATOR	1
	17P974	110V	
	17P975	220V	
410	---	NUT, M5	2
411	---	WASHER, lock	2
412	---	ROD, connector	2
413	17P977	HOUSING, motor	1
414		ARMATURE	1
	17P978	110V	
	17P979	220V	
415	17P980	DISK, guide	1
416	17P981	BEARING, lower	1
417	17P982	HOUSING, lower	1
418	---	SCREW, lower housing, M5 x 20mm	4
419†	17P984	COUPLING, motor	1
420	17P985	SCREW, ground, M4 x 6mm	1
421	17P986	WASHER, star, M4	1
422		ASSEMBLY, potentiometer	1
	17P987	110V	
	17P988	220V	
423		GASKET	1
	17P989	110V	
	17P990	220V	
424	17P991	HOUSING, switch	1
425		SCREW, switch housing	4
	---	110V, M5 x 16mm	
	---	220V, M5 x 25mm	
426		SWITCH, overload	1
	17P994	110V	
	17P995	220V	
427	---	LEAD, switch	2
428	17P997	FILTER, EMI	1
429	17P998	BLOCK, terminal	1
430	17P999	CLAMP, cable	1
431	---	SCREW, cable clamp	1

Ref.	Part	Description	Qty.
432		CORD, power	1
	17R001	110V	
	17R002	220V	
433	17R003	LEAD, earthing	1
434	17R004	COVER, switch	1
435	---	SCREW, switch cover	5

† Included in kit 25C572

Brush Kit

Part	Description	Qty.
25C562	KIT, brush, motor, ref 408	2
25C572	KIT, brush, motor, refs 408 (x2) and 419 (x1)	

Switch Kit

Part	Description	Qty.
25C567*	KIT, switch, 110V	1
25C568*	KIT, switch, 220V	1
* Includes 4 screws		

Hardware

Part	Description	Qty.
25C561	KIT, screws, ref 401	4
25C563	KIT, nuts, ref 410	2
25C564	KIT, washers, ref 411	2
25C565	KIT, rod, ref 412	2
25C566	KIT, screws, ref 418	4
25C567	KIT, screws, 110V motor, ref 425	4
25C568	KIT, screws, 220V motor, ref 425	4
25C569	KIT, lead, switch, ref 427	2
25C570	KIT, screws, ref 431	2
25C571	KIT, screws, switch cover, ref 435	5

Complete Pump Models 25C411, 25C412, 25C413, and 25C414

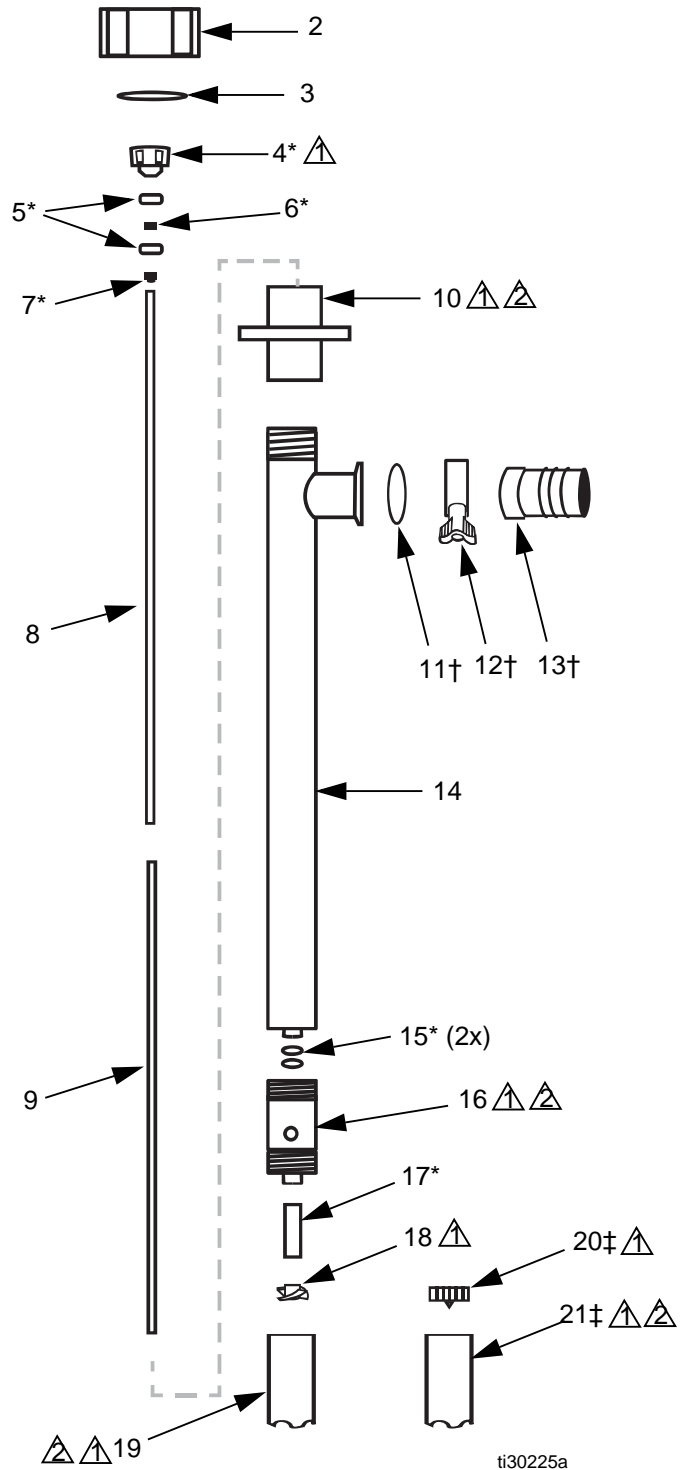
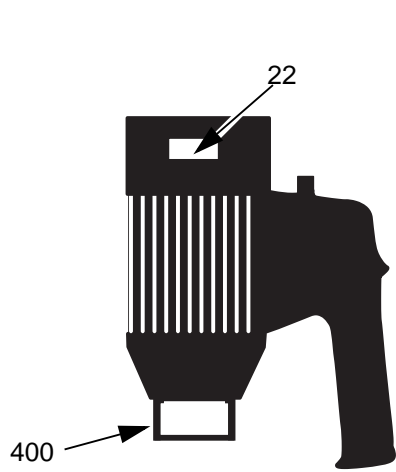

△ Hand tighten only.
 △△ Apply sanitary lubricant to threads.

ti30225a

Complete Pump Models 25C411, 25C412, 25C413, and 25C414

Ref.	Part	Description	Qty.
400		MOTOR,	1
	17N666	115 VAC	
	17N667	230 VAC	
2	17P642	NUT	1
3	17P621	SNAP RING	1
4*	17P620	COUPLING	1
5*	17P643	BEARING	2
6*	17P644	SPACER, bearing	1
7*	17P628	SEAL, PTFE	1
8		DRIVE SHAFT	1
	17P624	39 inch	
	17P625	47 inch	
9	17P631	GUIDE SLEEVE, PTFE	1
10	17P623	FLANGE, connection	1
11†	16D169	GASKET, Buna-N, (not included)	1
12†	118598	COUPLING, tri-clamp, (not included)	1
13†	17P480	HOSE BARB, for 1.5 in. ID hose (not included)	1
14		TUBE,	1
	17P626	39 inch	
	17P627	47 inch	
15*	17P636	O-RING, Buna-N	2
16	17P637	HOUSING, Pump	1
17*	17P638	BUSHING, PTFE	1
18	17P640	IMPELLER, low pressure, high flow (use with ref 19)	1
19	17P639	FOOT, low pressure	1
20‡	17P648	IMPELLER, high pressure, low flow (use with ref 21)	1
21‡	17P647	FOOT, high pressure	1
22▲	17S869	WARNING LABEL, English	1
	17S870	WARNING LABEL, multilingual	1

* Included in kit 25C505. Optional, ordered separately.

† Included in kit 25C502. Optional, ordered separately.

‡ Included in kit 25C507. Optional, ordered separately.

▲ Replacement warning labels are available at no cost.

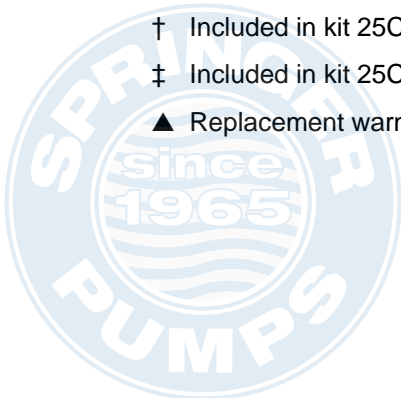

Complete Pump Models 25C420, 25C421, 25C780, 25C781

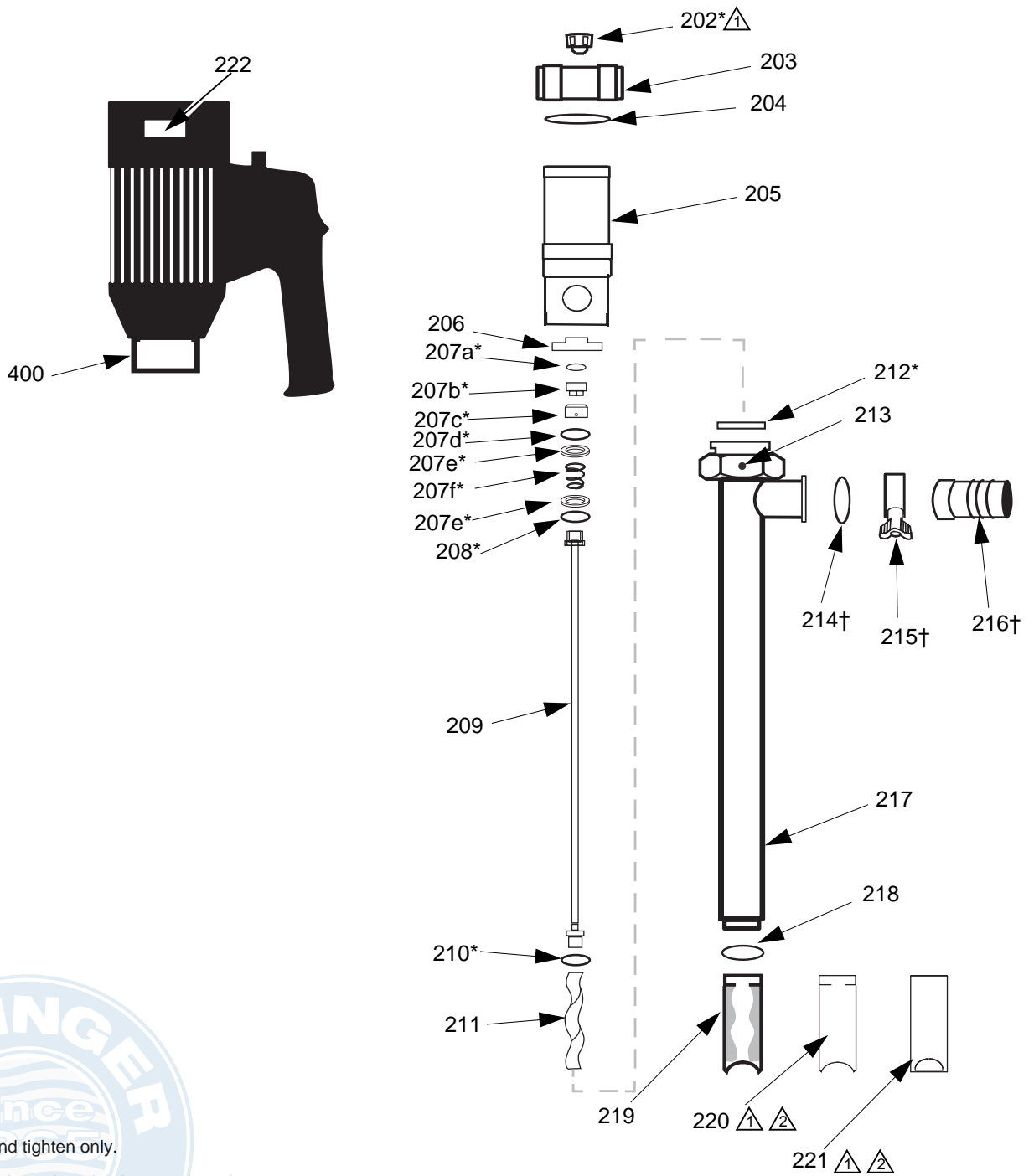

- Hand tighten only.
- Apply sanitary lubricant to threads.

ti30223a

Complete Pump Models 25C420, 25C421, 25C780, 25C781

Ref.	Part	Description	Qty.
400		MOTOR,	1
	17N666	115 VAC	
	17N667	230 VAC	
202*	17P620	COUPLING	1
203	17P642	NUT	1
204	17P621	SNAP RING	1
205	17P616	REDUCER, gear	1
206	17P603	BUSHING, mechanical seal	1
207*	17P604	SEAL, mechanical (includes ref 207a-207f)	1
207a	----	O-RING	1
207b	----	SEAL, upper	1
207c	----	SEAL, lower	1
207d	----	O-RING	1
207e	----	WASHER	2
207f	----	SPRING	1
208*	17P608	GASKET, PTFE	1
209	17P605	DRIVE SHAFT	1
210*	17P607	GASKET, PTFE	1
211	17P606	ROTOR	1
212*	17P609	GASKET, PTFE	1
213	17P612	SETSCREW	1
214†	16D169	GASKET, Buna-N, (not included)	1
215†	118598	COUPLING, tri-clamp, (not included)	1
216†	17P480	HOSE BARB, for 1.5 in. ID hose (not included)	1
217	17P617	TUBE, outer	1
218	17P602	RING	1
219	17P618	STATOR, PTFE	1
220	17P619	TUBE, stator	1
221	17S508	TUBE, stator, bag-liner	1
222▲	17S869	WARNING LABEL, English	1
	17S870	WARNING LABEL, multilingual	1

* Included in kit 25C503. Optional, ordered separately.

† Included in kit 25C502. Optional, ordered separately.

▲ Replacement warning labels are available at no cost.

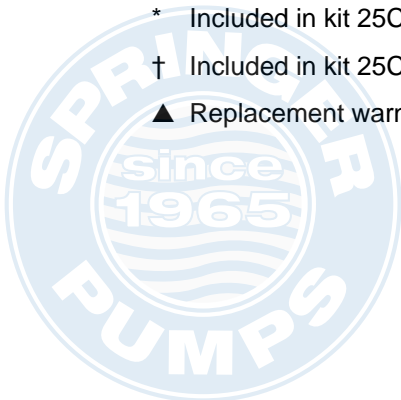

Complete Pump Models 25C416 - 25C419, 25C776 - 25C779

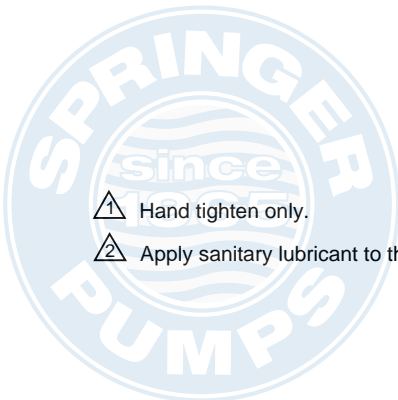
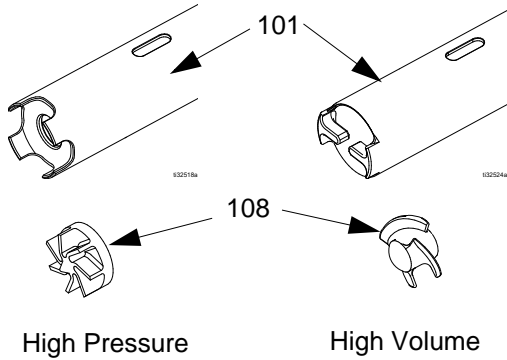
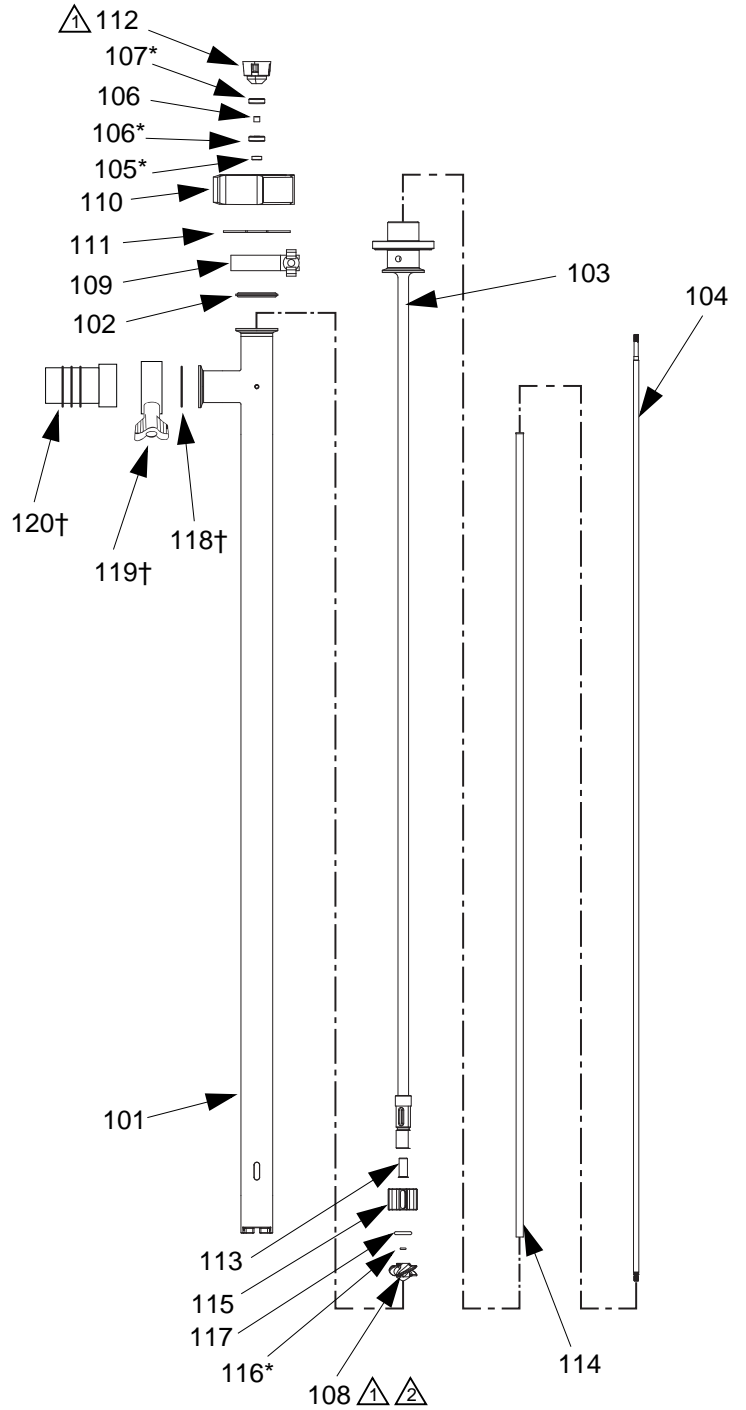
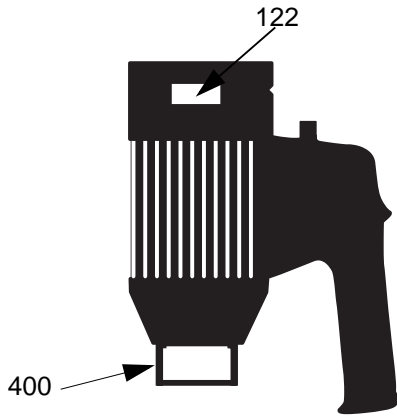

- ⚠ Hand tighten only.
- ⚠ Apply sanitary lubricant to threads.

ti32517a

Complete Pump Models 25C416 - 25C419, 25C776 - 25C779

Ref.	Part	Description	Qty.
400		MOTOR,	1
	17N666	115 VAC	
	17N667	230 VAC	
101		TUBE, outer	1
	17U558	high volume, 39 in.	
	17U564	high volume, 47 in.	
	17U567	high pressure, 39 in.	
	17U568	high pressure, 47 in.	
102	16D169	SEAL	1
103		TUBE, inner	1
	17U559	39 in.	
	17U565	47 in.	
104		DRIVE SHAFT	1
	17U560	39 in.	
	17U566	47 in.	
105*	17P628	SEAL	1
106*	17P644	SPACER, bearing	1
107*	17P643	BEARING	2
108		IMPELLER	1
	17P640	high volume	
	17P648	high pressure	
109	118598	COUPLING, tri-clamp	1
110	17U562	COUPLING, 3A	1
111	17P621	SNAP RING	1
112*	17P620	COUPLING	1
113	17P638	BUSHING, PTFE	1
114	17P631	SLEEVE, guide	1
115	17U563	SPACER	1
116*	17P641	O-RING	1
117*	17U576	O-RING	1
118†	16D169	GASKET, Buna-N, (not included)	1
119†	118598	COUPLING, tri-clamp, (not included)	1
120†	17P480	HOSE BARB, for 1.5 in. ID hose (not included)	1
122▲	17S869	WARNING LABEL, English	1
	17S870	WARNING LABEL, multilingual	1

* Included in kit 25D509. Optional, ordered separately.

† Included in kit 25C502. Optional, ordered separately.

▲ Replacement warning labels are available at no cost.

Complete Pump Model 25C422, 25C782

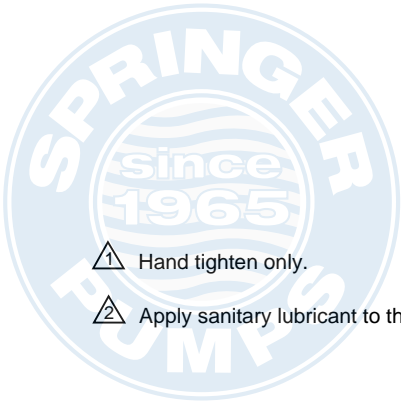
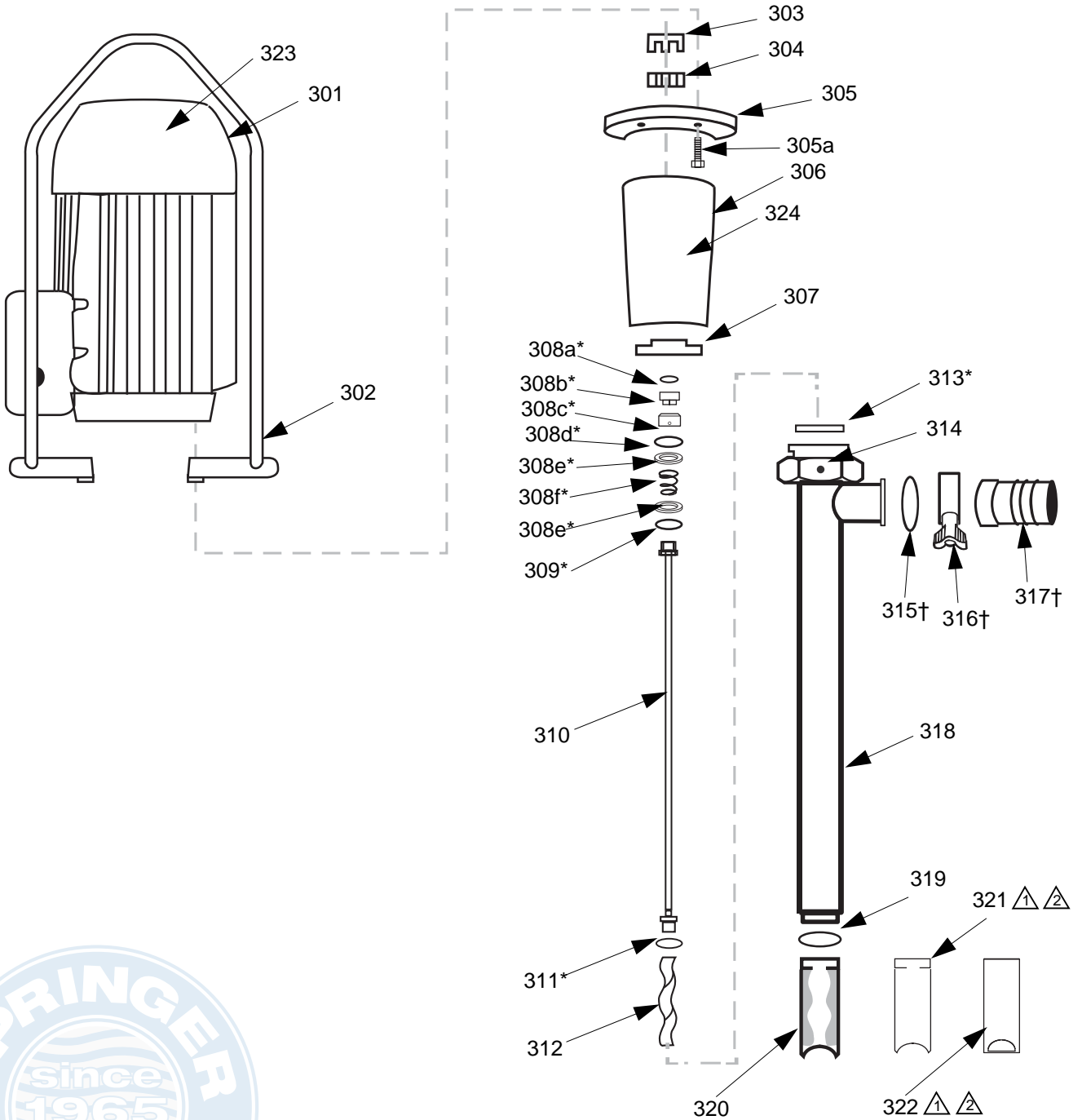

- ⚠ Hand tighten only.
- ⚠ Apply sanitary lubricant to threads.

ti30224a

Complete Pump Model 25C422, 25C782

Ref.	Part	Description	Qty.
301	17P668	MOTOR	1
302	17P622	HANGER, motor	1
303	17P611	COUPLING	1
304	17P610	INSERT, coupling	1
305	17P615	FLANGE, motor mount	1
305a	17P613	BOLT (long bolts for attaching item 302)	6
306	17P614	HOUSING	1
307	17P603	BUSHING, mechanical seal	1
308*	17P604	SEAL, mechanical (includes ref 308a-308f)	1
308a	----	O-RING	1
308b	----	SEAL, upper	1
308c	----	SEAL, lower	1
308d	----	O-RING	1
308e	----	WASHER	2
308f	----	SPRING	1
309*	17P608	GASKET, PTFE	1
310	17P605	DRIVE SHAFT	1
311*	17P607	GASKET, PTFE	1
312	17P606	ROTOR	1
313*	17P609	GASKET, PTFE	1
314	17P612	SETSCREW	1
315†	16D169	GASKET, Buna-N, (not included)	1
316†	118598	COUPLING, tri-clamp, (not included)	1
317†	17P480	HOSE BARB, for 1.5 in. ID hose (not included)	1
318	17P617	TUBE, outer	1
319	17P602	RING	1
320	17P618	STATOR, PTFE	1
321	17P619	TUBE, stator	1
322	17S508	TUBE, stator, bag-liner	1
323▲	17S869	WARNING LABEL, English	1
	17S870	WARNING LABEL, multilingual	1
324▲	15H108	WARNING LABEL, pinch	1

* Included in kit 25C504. Optional, ordered separately.

† Included in kit 25C502. Optional, ordered separately.

▲ Replacement warning labels are available at no cost.

Performance Charts

Models 25C411 - 25C419, 25C776 - 25C779

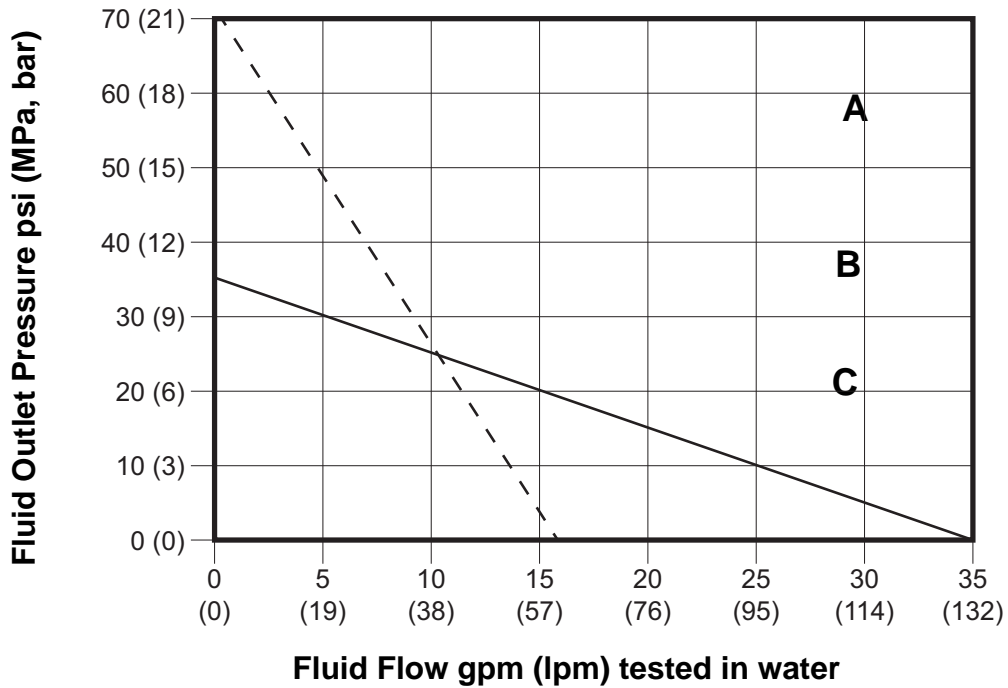

Key:

- - - - Flow with optional high pressure kit 25C507 installed, or high pressure 3A pump
- Flow with as-purchased low pressure impeller, or low pressure 3A pump

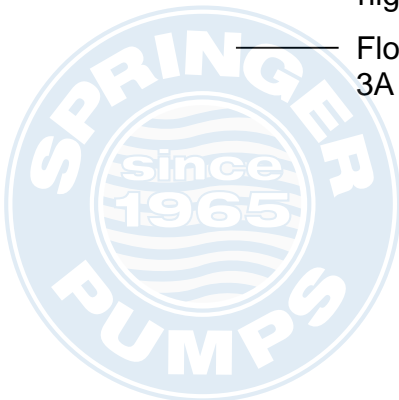

Models 25C420 - 25C421, 25C780 - 25C781

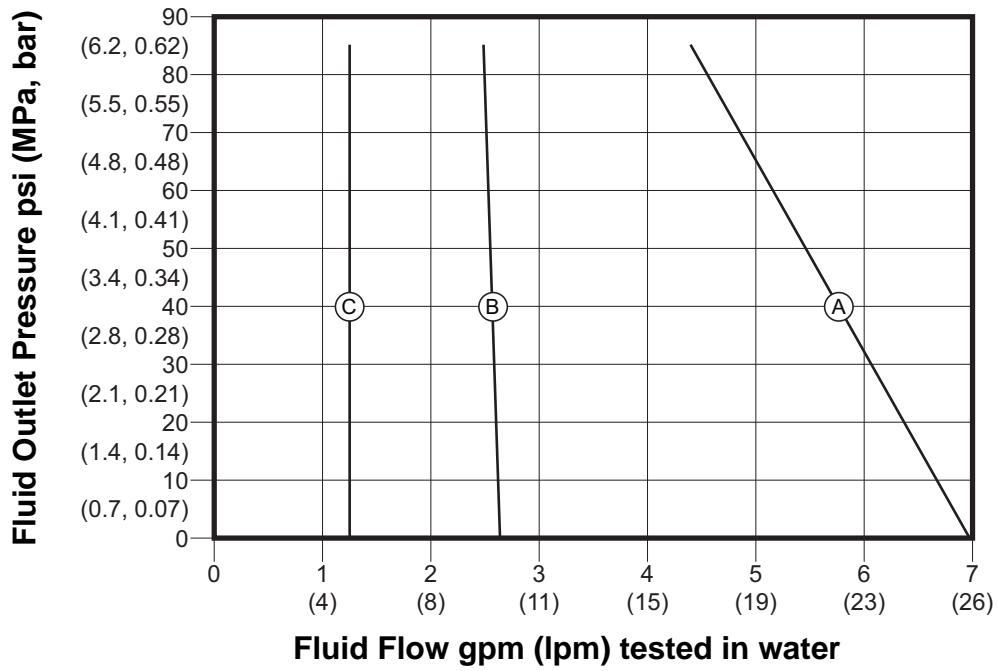

Viscosity, cps
A: 1
B: 10,000
C: 25,000



3A4586E

Tel: 866-777-6060
Fax: 866-777-6383

Springer Pumps, LLC

Website: www.springerpumps.com
Int'l: +001 267 404 2910

Model 25C422, 25C782

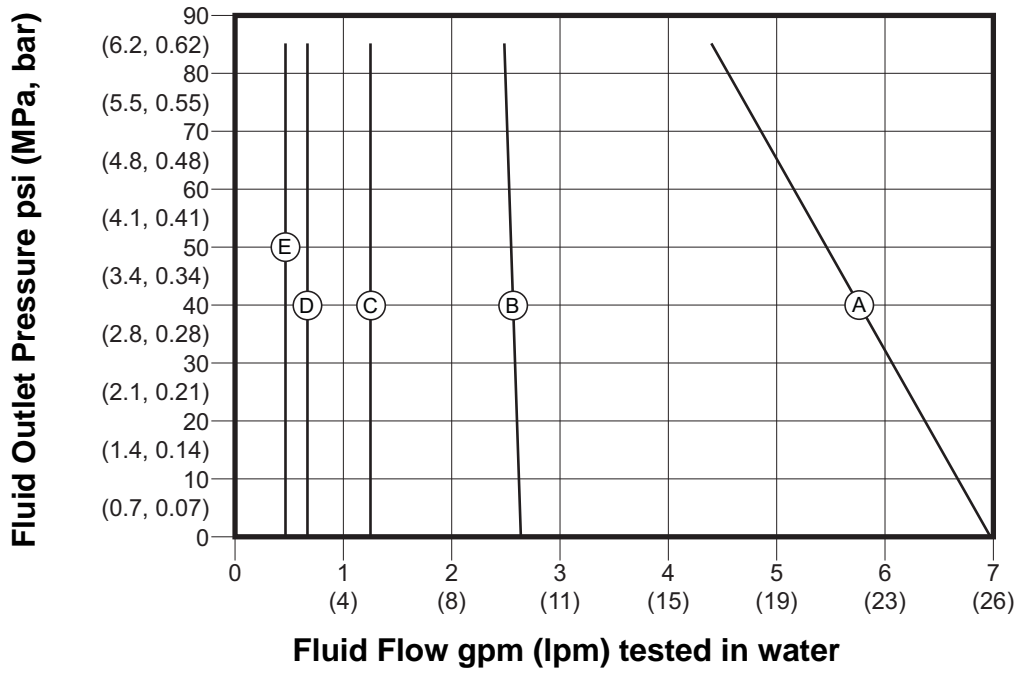

Viscosity, cps
A: 1
B: 10,000
C: 30,000
D: 60,000
E: 100,000



Dimensions

All values are nominal.

**Models 25C411, 25C412,
25C416, 25C417, 25C776,
25C777**

**Models 25C413, 25C414,
25C418, 25C419, 25C778,
25C779**

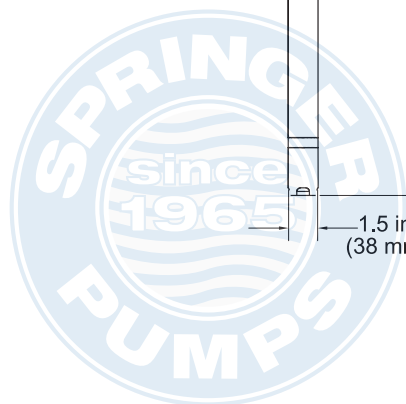
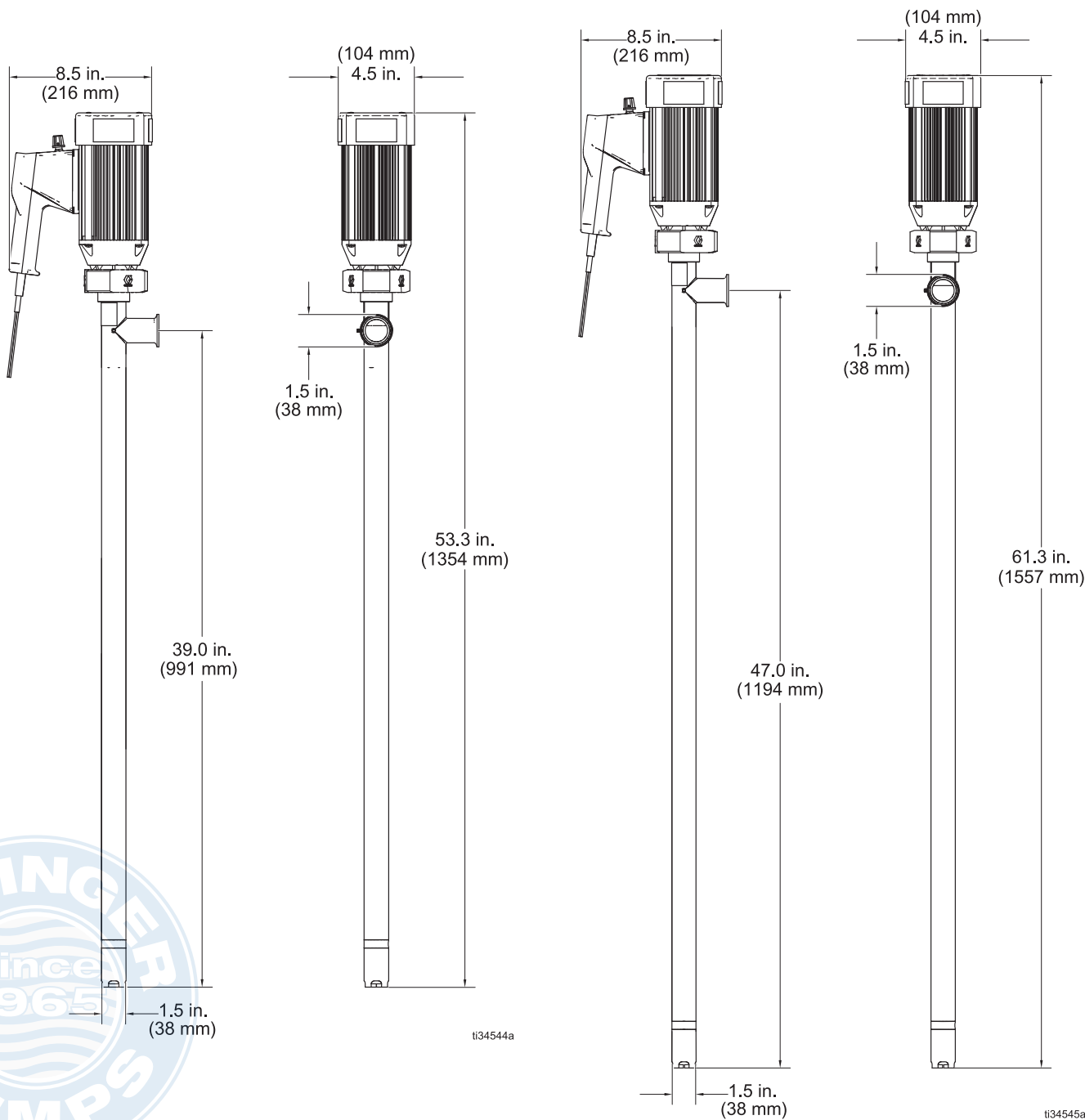

3A4586E

Tel: 866-777-6060
Fax: 866-777-6383

Springer Pumps, LLC

Website: www.springerpumps.com
Int'l: +001 267 404 2910

**Models 25C420, 25C421,
25C780, 25C781**

Models 25C422, 25C782

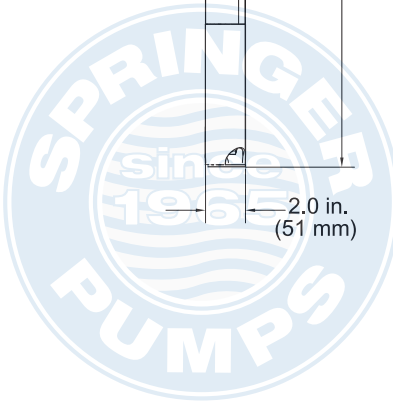
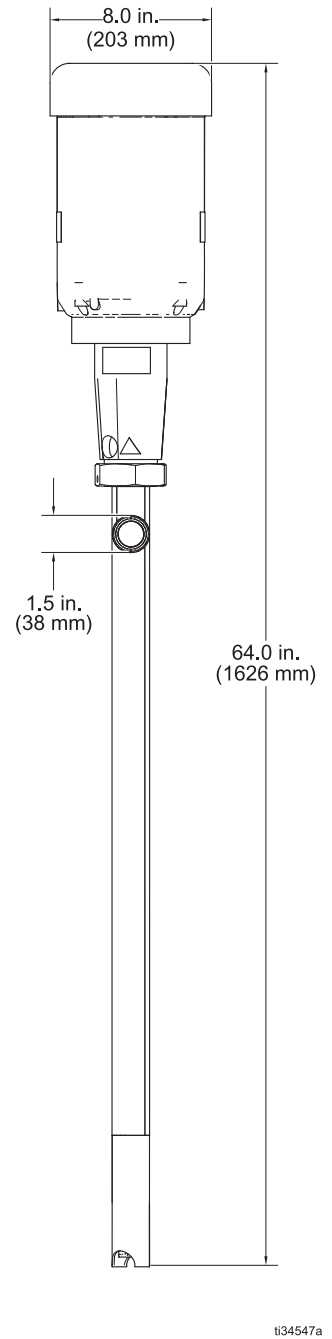
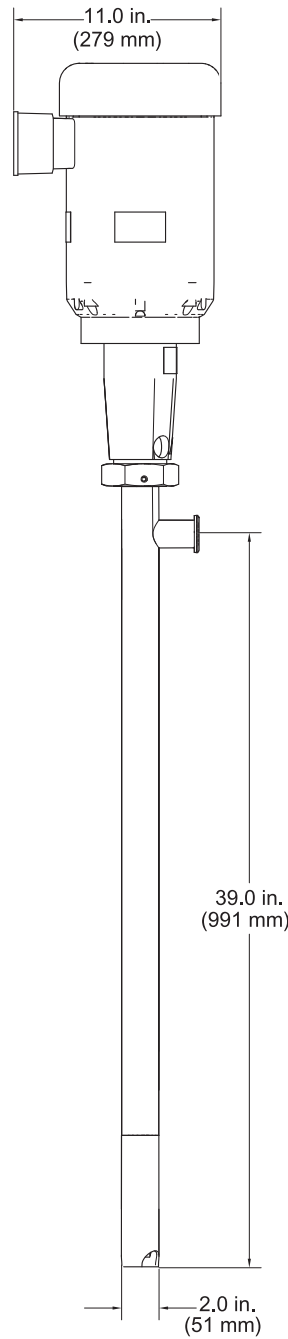
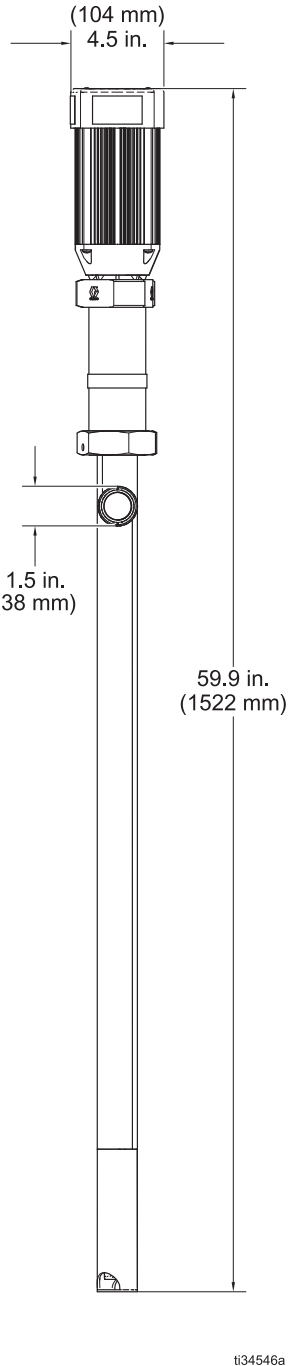
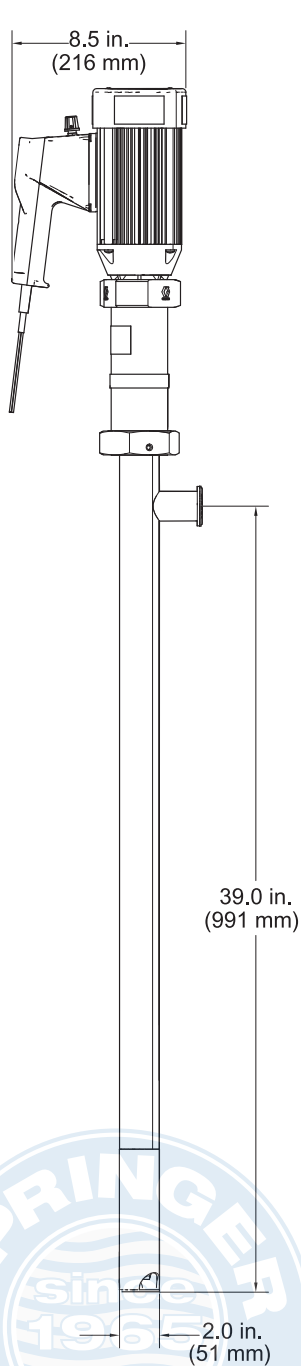

i134546a

i134547a

Technical Data

Maximum Fluid Working Pressure	
Centrifugal	43 psi (0.3 MPa, 3 bar)
Progressive cavity	87 psi (0.6 MPa, 6 bar)
Maximum operating temperature	
Centrifugal	175°F (80°C)
Progressive cavity	185°F (85°C)
Fluid Outlet	1.5 in. Tri-clamp®
17N668 Motor Power	1.5 Hp/1.1 kW
Frequency, Hz	
AC Voltage	
Amperage	
RPM	
Weight, motor	
17N666, 17N667	13 lb (5.9 kg)
17N668	80 lb (36.3 kg)
Motor Power Cable Length	
17N666, 17N667	16 ft (4.9 m)
Weight, lowers	
17N669	11 lb (5 kg)
17N670	13 lb (5.9 kg)
17N673, 17S150	24 lb (10.9 kg)
17N674, 17S153	23 lb (10.4 kg)
Wetted Parts (all pumps)	316 Stainless Steel, Buna-N, PTFE
Progressive cavity pumps also contain	Silicone Carbide, Viton®
Maximum Viscosity	
17N669-17N670	1,000 cps (mPa-s)
17N673, 17S150	25,000 cps (mPa-s)
17N674, 17S153	100,000 cps (mPa-s)
Duty Cycle	Intermittent when operating at maximum viscosity; continuous for 25C422, 25C782 pump
Maximum Flow Rate	
Centrifugal	35 gpm (132 lpm)
Progressive cavity	7 gpm (26 lpm)
Maximum Solids Size	
Centrifugal	Not recommended for fluids which contain solids
Progressive cavity	0.25 in. (6 mm)
Sound data	
Sound pressure (pumps with 17N666 and 17N667 motor); (tested 3.28 feet (1 m) from equipment at maximum pump speed pumping water)	84 dBA

50	60
190/380	230/460
6.4/3.2	5.8/2.9
700	850

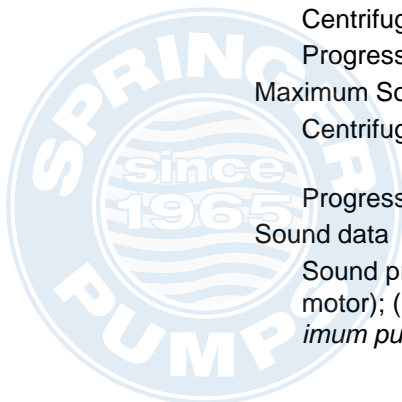

ISSUE DATE: June 20, 2017

CERTIFICATE AUTHORIZATION NUMBER: 3588



THIS IS TO CERTIFY THAT

Graco, Inc.

88 - 11th Avenue, NE, Minneapolis, MN 55413

is hereby authorized to continue to apply the
3-A Symbol to the models of equipment, conforming to 3-A Sanitary Standards for:

Number 02-11
02-11 (Centrifugal and Positive Rotary Pumps)

set forth below

COP Models: Centrifugal Drum Pumps 17N671, 17N672, 17S148, 17S149

VALID THROUGH: **December 31, 2018**

Timothy R. Rugh
Executive Director
3-A Sanitary Standards, Inc.

The issuance of this authorization for the use of the 3-A Symbol is based upon the voluntary certification, by the applicant for it, that the equipment listed above complies fully with the 3-A Sanitary Standard(s) designated. Legal responsibility for compliance is solely that of the holder of this Certificate of Authorization, and 3-A Sanitary Standards, Inc. does not warrant that the holder of an authorization at all times complies with the provisions of the said 3-A Sanitary Standards. This in no way affects the responsibility of 3-A Sanitary Standards, Inc. to take appropriate action in such cases in which evidence of nonconformance has been established.

NEXT TPV INSPECTION/REPORT DUE: **May 2022**

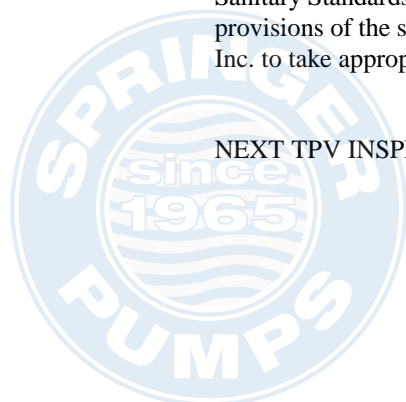

3A4586E

Tel: 866-777-6060
Fax: 866-777-6383

Springer Pumps, LLC

Website: www.springerpumps.com
Int'l: +001 267 404 2910

Graco Standard Warranty

Graco warrants all equipment referenced in this document which is manufactured by Graco and bearing its name to be free from defects in material and workmanship on the date of sale to the original purchaser for use. With the exception of any special, extended, or limited warranty published by Graco, Graco will, for a period of twelve months from the date of sale, repair or replace any part of the equipment determined by Graco to be defective. This warranty applies only when the equipment is installed, operated and maintained in accordance with Graco's written recommendations.

This warranty does not cover, and Graco shall not be liable for general wear and tear, or any malfunction, damage or wear caused by faulty installation, misapplication, abrasion, corrosion, inadequate or improper maintenance, negligence, accident, tampering, or substitution of non-Graco component parts. Nor shall Graco be liable for malfunction, damage or wear caused by the incompatibility of Graco equipment with structures, accessories, equipment or materials not supplied by Graco, or the improper design, manufacture, installation, operation or maintenance of structures, accessories, equipment or materials not supplied by Graco.

This warranty is conditioned upon the prepaid return of the equipment claimed to be defective to an authorized Graco distributor for verification of the claimed defect. If the claimed defect is verified, Graco will repair or replace free of charge any defective parts. The equipment will be returned to the original purchaser transportation prepaid. If inspection of the equipment does not disclose any defect in material or workmanship, repairs will be made at a reasonable charge, which charges may include the costs of parts, labor, and transportation.

THIS WARRANTY IS EXCLUSIVE, AND IS IN LIEU OF ANY OTHER WARRANTIES, EXPRESS OR IMPLIED, INCLUDING BUT NOT LIMITED TO WARRANTY OF MERCHANTABILITY OR WARRANTY OF FITNESS FOR A PARTICULAR PURPOSE.

Graco's sole obligation and buyer's sole remedy for any breach of warranty shall be as set forth above. The buyer agrees that no other remedy (including, but not limited to, incidental or consequential damages for lost profits, lost sales, injury to person or property, or any other incidental or consequential loss) shall be available. Any action for breach of warranty must be brought within two (2) years of the date of sale.

GRACO MAKES NO WARRANTY, AND DISCLAIMS ALL IMPLIED WARRANTIES OF MERCHANTABILITY AND FITNESS FOR A PARTICULAR PURPOSE, IN CONNECTION WITH ACCESSORIES, EQUIPMENT, MATERIALS OR COMPONENTS SOLD BUT NOT MANUFACTURED BY GRACO. These items sold, but not manufactured by Graco (such as electric motors, switches, hose, etc.), are subject to the warranty, if any, of their manufacturer. Graco will provide purchaser with reasonable assistance in making any claim for breach of these warranties.

In no event will Graco be liable for indirect, incidental, special or consequential damages resulting from Graco supplying equipment hereunder, or the furnishing, performance, or use of any products or other goods sold hereto, whether due to a breach of contract, breach of warranty, the negligence of Graco, or otherwise.

FOR GRACO CANADA CUSTOMERS

The Parties acknowledge that they have required that the present document, as well as all documents, notices and legal proceedings entered into, given or instituted pursuant hereto or relating directly or indirectly hereto, be drawn up in English. Les parties reconnaissent avoir convenu que la rédaction du présente document sera en Anglais, ainsi que tous documents, avis et procédures judiciaires exécutés, donnés ou intentés, à la suite de ou en rapport, directement ou indirectement, avec les procédures concernées.

Graco Information

For the latest information about Graco products, visit www.graco.com.

For patent information, see www.graco.com/patents.

TO PLACE AN ORDER, contact your Graco distributor or call to identify the nearest distributor.

Phone: 612-623-6921 **or Toll Free:** 1-800-328-0211 **Fax:** 612-378-3505

All written and visual data contained in this document reflects the latest product information available at the time of publication. Graco reserves the right to make changes at any time without notice.

Original instructions. This manual contains English. MM 3A4586

Graco Headquarters: Minneapolis

International Offices: Belgium, China, Japan, Korea

GRACO INC. AND SUBSIDIARIES • P.O. BOX 1441 • MINNEAPOLIS MN 55440-1441 • USA

Copyright 2017, Graco Inc. All Graco manufacturing locations are registered to ISO 9001.

www.graco.com

Revision E - October 2018