

Instructions/Parts



SaniForce® 2:1 Sanitary Piston

Pumps

3A2977L
EN

For use in sanitary applications to transfer low- to medium-viscosity fluids. Use with non-flammable liquids only. For professional use only.



Important Safety Instructions

Read all warnings and instructions in this manual.

Save these instructions.

*Maximum Fluid Working Pressure: 250
psi (1.7 MPa, 17.0 bar)*



ti19915a

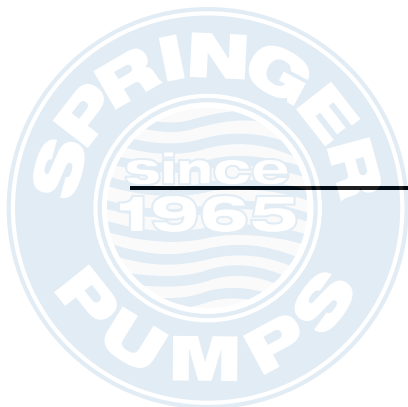

PROVEN QUALITY. LEADING TECHNOLOGY.

Contents

Models.....	3	Troubleshooting.....	10
Warnings	4	Repair.....	11
Installation.....	6	Disconnect the Air Motor	11
Grounding	6	Air Motor Disassembly	11
Mounting	6	Air Motor Reassembly	13
Setup	6	Disassemble the Pump.....	15
Operation.....	8	Reassemble After Cleaning	16
Pressure Relief Procedure.....	8	Reconnect The Pump.....	17
Flush Before First Use.....	8	Parts.....	18
Adjusting the Pump Speed and		Kits and Accessories.....	24
Pressure	8	Dimensions	25
Pump Shut Down.....	8	Performance Chart	26
Maintenance	9	Technical Data	27
Flushing Procedure	9	Graco Standard Warranty.....	28
Cleaning.....	9		
Tighten Threaded Connections	9		



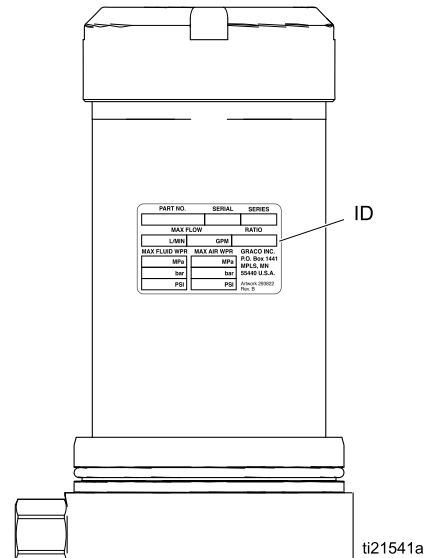

Models

See ID tag on side of air motor
(located under the motor cover) for
model number.



Maximum Air Inlet Pressure: 100 psi (0.7 MPa, 6.9 bar)
Maximum Fluid Working Pressure: 250 psi (1.7 MPa, 17.0 bar)

Pump Model	Pump Type	Pump Description	Packings
24N300	Double Ball	Tall Drum Length (42 in., 107 cm Drum)	U-Cup, UHMWPE
24N344	Double Ball	Tall Drum Length (42 in., 107 cm Drum)	U-Cup, PTFE
24R046	Double Ball	Standard Drum Length (34 in., 86 cm Drum)	U-Cup, UHMWPE
24R047, 24R047C31†	Double Ball	Standard Drum Length (34 in., 86 cm Drum)	U-Cup, PTFE
   <p>II 2 GD Ex h IIA T3 Gb Ex h IIIB T158°C Db</p>			<p>NOTE: See page 4 for FDA Material Certification.</p>

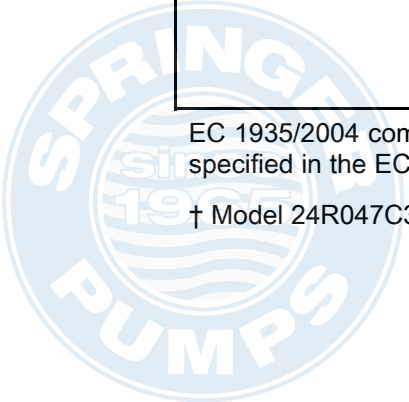

EC 1935/2004 compliant pumps may be subject to individual national provisions in addition to those specified in the EC regulation. It is the users responsibility to know and follow local laws.

† Model 24R047C31 is the same as 24R047, except that it is type 3.1 certified per DS/EN 10204.



Warnings

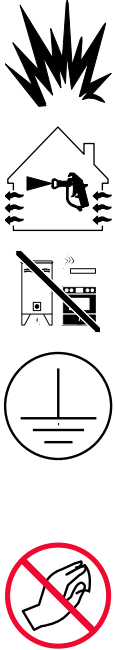

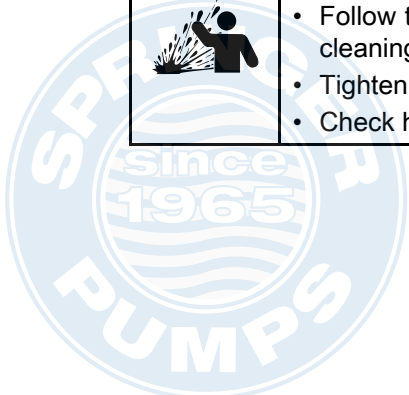

The following warnings are for the setup, use, grounding, maintenance and repair of this equipment. The exclamation point symbol alerts you to a general warning and the hazard symbol refers to procedure-specific risks. When these symbols appear in the body of this manual or on labels refer back to these Warnings. Product-specific hazard symbols and warnings not covered in this section may appear throughout the body of this manual where applicable.

 WARNING	
	<p>FIRE AND EXPLOSION HAZARD</p> <p>Flammable fumes, such as solvent and paint fumes, in work area can ignite or explode. To help prevent fire and explosion:</p> <ul style="list-style-type: none"> • Use equipment only in well ventilated area. • Eliminate all ignition sources; such as pilot lights, cigarettes, portable electric lamps, and plastic drop cloths (potential static arc). • Keep work area free of debris, including solvent, rags and gasoline. • Do not plug or unplug power cords, or turn power or light switches on or off when flammable fumes are present. • Ground all equipment in the work area. See Grounding instructions. • Use only grounded hoses. • Hold gun firmly to side of grounded pail when triggering into pail. Do not use pail liners unless they are antistatic or conductive. • Stop operation immediately if static sparking occurs or you feel a shock, Do not use equipment until you identify and correct the problem. • Keep a working fire extinguisher in the work area. <p>Static charge may build up on plastic parts during cleaning and could discharge and ignite flammable vapors. To help prevent fire and explosion:</p> <ul style="list-style-type: none"> • Clean plastic parts only in well ventilated area. • Do not clean with a dry cloth.
	<p>PRESSURIZED EQUIPMENT HAZARD</p> <p>Fluid from the equipment, leaks, or ruptured components can splash in the eyes or on skin and cause serious injury.</p> <ul style="list-style-type: none"> • Follow the Pressure Relief Procedure when you stop spraying/dispensing and before cleaning, checking, or servicing equipment. • Tighten all fluid connections before operating the equipment. • Check hoses, tubes, and couplings daily. Replace worn or damaged parts immediately.







WARNING

 	<p>EQUIPMENT MISUSE HAZARD</p> <p>Misuse can cause death or serious injury.</p> <ul style="list-style-type: none"> • Do not operate the unit when fatigued or under the influence of drugs or alcohol. • Do not exceed the maximum working pressure or temperature rating of the lowest rated system component. See Technical Data in all equipment manuals. • Use fluids and solvents that are compatible with equipment wetted parts. See Technical Data in all equipment manuals. Read fluid and solvent manufacturer's warnings. For complete information about your material, request MSDS from distributor or retailer. • Turn off all equipment and follow the Pressure Relief Procedure when equipment is not in use. • Check equipment daily. Repair or replace worn or damaged parts immediately with genuine manufacturer's replacement parts only. • Do not alter or modify equipment. Alterations or modifications may void agency approvals and create safety hazards. • Make sure all equipment is rated and approved for the environment in which you are using it. • Use equipment only for its intended purpose. Call your distributor for information. • Route hoses and cables away from traffic areas, sharp edges, moving parts, and hot surfaces. • Do not kink or over bend hoses or use hoses to pull equipment. • Keep children and animals away from work area. • Comply with all applicable safety regulations.
	<p>PLASTIC PARTS CLEANING SOLVENT HAZARD</p> <p>Many solvents can degrade plastic parts and cause them to fail, which could cause serious injury or property damage.</p> <ul style="list-style-type: none"> • Use only compatible water-based solvents to clean plastic structural or pressure-containing parts. • See Technical Data in this and all other equipment instruction manuals. Read fluid and solvent manufacturer's MSDSs and recommendations.
	<p>TOXIC FLUID OR FUMES HAZARD</p> <p>Toxic fluids or fumes can cause serious injury or death if splashed in the eyes or on skin, inhaled, or swallowed.</p> <ul style="list-style-type: none"> • Read MSDSs to know the specific hazards of the fluids you are using. • Store hazardous fluid in approved containers, and dispose of it according to applicable guidelines.
	<p>PERSONAL PROTECTIVE EQUIPMENT</p> <p>Wear appropriate protective equipment when in the work area to help prevent serious injury, including eye injury, hearing loss, inhalation of toxic fumes, and burns. This protective equipment includes but is not limited to:</p> <ul style="list-style-type: none"> • Protective eyewear, and hearing protection. • Respirators, protective clothing, and gloves as recommended by the fluid and solvent manufacturer.

Installation

Grounding

			
<p>The equipment must be grounded to reduce the risk of static sparking. Static sparking can cause fumes to ignite or explode. Grounding provides an escape wire for the electrical current.</p>			

Pump: Connect a ground wire (Graco PN 238909) to the ground screw on the air motor base. Connect the other end of the ground wire to a true earth ground.

Air and fluid hoses: Use only electrically conductive hoses with a maximum of 500 ft. (150 m) combined hose length to ensure grounding continuity. Check electrical resistance of hoses. If total resistance to ground exceeds 25 megohms, replace hose immediately.

Air compressors: Follow manufacturer's recommendations.

Dispense valve: Ground through connection to a properly grounded fluid hose and pump.

Material supply container: Follow local code.

Container(s) that receive material: Follow local code.

Solvent pails used when flushing: Follow local code. Use only conductive metal pails, placed on a grounded surface. Do not place the pail on a nonconductive surface, such as paper or cardboard, which interrupts grounding continuity.



To maintain grounding continuity when flushing or relieving pressure: Hold metal part of the dispense valve firmly to the side of a grounded metal pail, then trigger the valve.

Mounting

Mount the pump to fully support the weight of the pump and accessories, as well as the stress caused

during operation. Do not use air or fluid lines to support the pump.

Setup

					
<p>To avoid contaminating the fluid, pipe the exhaust air to vent outside of the fluid product area, away from people, animals, or food handling areas.</p>					

Note

Reference numbers and letters in parentheses in the text refer to the callouts in the figures and the parts drawings.

Accessories are available from Graco. Make certain all accessories are sized and pressure rated to meet your system requirements.

Figure 1 is only a guide for selecting and installing system components and accessories. Contact your Graco distributor for assistance in designing a system to suit your particular needs.

Install a fluid drain valve (P) close to the fluid outlet to relieve fluid pressure in the hose.

Install a bleed-type master air valve (G) close to the pump air inlet (D), to relieve air trapped between it and the air motor.

Install an air filter/regulator (F) in the pump air line, *upstream from the bleed valve*, to control air inlet pressure and to remove harmful dirt and contaminants from your compressed air supply.

Install a pump runaway valve (L) in the pump air line to shut off air to the air motor automatically if the pump starts to run too fast.

Install another bleed-type master air valve (G) upstream from all air line accessories and use it to isolate the accessories during cleaning and repair.



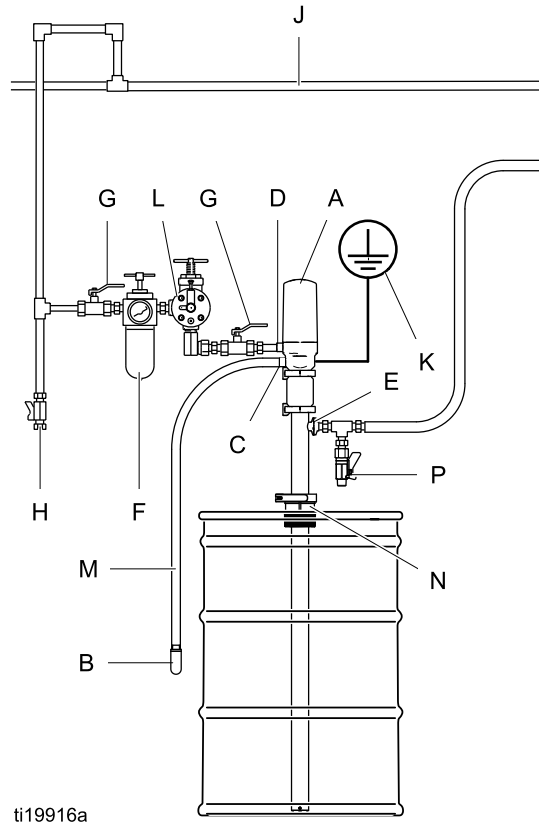

Figure 1 Typical Installation

Key

Pump Components (Included)

- A Bung-mounted sanitary pump
- B Air exhaust muffer (may be mounted on pump or remotely, using exhaust hose, ref. M)
- C 3/8 npt exhaust air outlet
- D 3/8 npt air inlet
- E 1 in. tri-clamp flanged fluid outlet (Order Kit 24R649 for adapter to 25 mm threaded DIN 11851. See [Accessories, page 24.](#))



System Components/Accessories (sold separately)

- F Air line filter/regulator (Graco PN 234398)
- G Bleed-type master air valve (required)
- H Air line drain pipe and valve
- J Main air line
- K Pump ground wire (required, Graco PN 238909)
- L Pump runaway valve
- M Exhaust hose, Kit 24R646, see [Accessories, page 24.](#)
- N Sanitary bung adapter
- P Fluid drain valve (required)



Operation



NOTICE				
<p>Do not expose the air motor to temperatures higher than 120°F (49°C) or the immersed fluid pump to temperatures higher than 250°F (121°C). Excessive temperatures may damage the pump packings and seals.</p>				

				
<p>To avoid injury from exhaust hose whip, never operate the pump without a muffler installed. Secure the exhaust hose to a solid, stationary object.</p>				

Pressure Relief Procedure



Follow the Pressure Relief Procedure whenever you see this symbol.

				
<p>This equipment stays pressurized until pressure is manually relieved. To help prevent serious injury from pressurized fluid, such as splashing in the eyes or on skin, follow the Pressure Relief Procedure when you stop dispensing and before cleaning, checking, or servicing the equipment.</p>				

1. Shut off the air supply to the pump.
2. Close the bleed-type master air valve (required in system).
3. Open the fluid ball valve and/or dispensing valve to relieve fluid pressure.
4. Open all fluid drain valves in the system, having a waste container ready to catch drainage. Leave drain valve(s) open until you are ready to dispense again.

Flush Before First Use

The sanitary pump was assembled using sanitary lubricant on moving parts and was tested in water. Flush the pump thoroughly with an appropriate cleaning solution or disassemble and sanitize the parts before using the pump. See [Flushing Procedure, page 9](#) . Check national, state, and local codes for specific limitations.

Adjusting the Pump Speed and Pressure

Set pressure regulator to 0 psi. Open the bleed-type master air valve. Adjust the pump air regulator until the pump is running smoothly.

Allow the pump to cycle slowly until all air is pushed out of the lines (the fluid will flow in a steady stream from the fluid outlet) and the pump is primed.

With the air supply turned on, the pump will start when the dispensing valve is opened and stall against pressure when the valve is closed. In a circulating system, the pump operates until the air supply is turned off.

NOTICE				
<p>Never allow the pump to run dry of fluid. A dry pump will accelerate to a high speed, possibly damaging itself.</p>				

If the pump accelerates quickly, or is running too fast, stop the pump immediately and check the fluid supply. If the supply is empty and air has been pumped into the lines, replace the container and prime the pump and lines with fluid. Be sure to eliminate all air from the system.

Pump Shut Down

Follow the [Pressure Relief Procedure, page 8](#) .

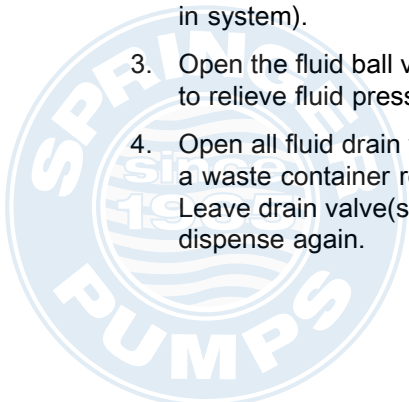

Maintenance

Flushing Procedure



Note:

- Flush before fluid can dry in the equipment, at the end of the day, before storing, and before repairing equipment.
 - Flush at the lowest pressure possible. Check connectors for leaks and tighten as necessary.
 - Flush with an appropriate cleaning solution.
1. Follow [Pressure Relief Procedure, page 8](#) .
 2. Remove the pump from the fluid container. Place it in an empty drum. Operate it to pump out as much fluid as possible.
 3. Place siphon tube in grounded metal pail containing an appropriate cleaning solution.
 4. Set pump air regulator to lowest possible fluid pressure, and start pump.
 5. Run the pump long enough to thoroughly clean the pump and hoses.
 6. Follow [Pressure Relief Procedure, page 8](#) .

Cleaning

- **Be sure** to follow your national and state sanitary standard codes and local regulations.
- Use appropriate cleaning and disinfecting agents, at intervals appropriate for product processed.
- Follow cleaning product manufacturer's instructions.

Note: The pump lower **must be disassembled** to thoroughly clean it.

1. Follow the [Pressure Relief Procedure, page 8](#) .

2. Remove the pump from the fluid container. Place it in an empty drum Operate it to pump out as much fluid as possible.
3. Flush the system thoroughly with an appropriate cleaning solution. See [Flushing Procedure, page 9](#) .
4. Follow the [Pressure Relief Procedure, page 8](#) .
5. Remove the air and fluid hoses and fittings from the pump.
6. Disassemble the fluid pump and accessories. See [Disassemble the Pump, page 15](#).
7. Wash all pump parts with an appropriate cleaning solution at the cleaning product manufacturer's recommended temperature and concentration.
8. Rinse all pump parts again with water and allow them to dry.
9. Inspect all pump parts and reclean if needed.

Note

Any damaged rubber parts **must** be replaced as they could harbor microorganisms that can contaminate the fluid.

10. Immerse all pump parts in an appropriate sanitizer before assembly. Take the pump parts out of the sanitizer one-by-one as needed.
11. Lubricate the moving pump parts and o-rings, packings, and seals with appropriate waterproof sanitary lubricant.
12. Circulate the sanitizing solution through the pump and the system prior to use.

Tighten Threaded Connections

Before each use, check all hoses for wear or damage. Replace as necessary. Check that all connections are tight and leak-free.

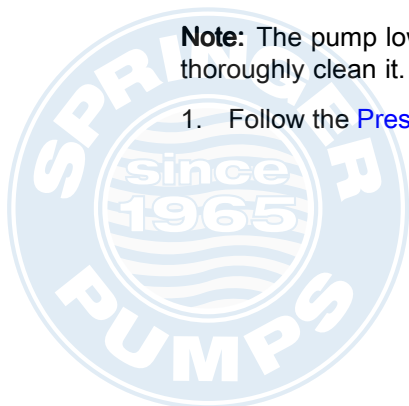

Troubleshooting



1. Follow [Pressure Relief Procedure, page 8](#) .
2. Check all possible remedies in the Troubleshooting Chart before disassembling the pump.

Problem	Cause	Solution
Pump cycles, but no fluid comes out.	Fluid supply is empty.	Replace fluid supply.
Pump cycles, but fluid flow is too slow.	Air supply flow or pressure is inadequate.	Improve air supply flow, increase pressure, or increase air line size.
	Air valves are closed or clogged.	Open air line. Use dry air.
	Air line is closed or clogged.	Remove obstruction.
	Fluid line is obstructed.	Remove obstruction.
	Fluid line is too small.	Increase size of fluid line.
	Fluid is too thick.	Reduce viscosity of fluid by heat or dilution.
Pump dives and/or does not pump on upstroke.	Pump rod check seat or seals are worn out or missing.	Replace check seat or seals.
Pump dives and/or does not pump on downstroke.	Inlet check seat or seals are worn out or missing.	Replace inlet check seat or seals.
	Fluid inlet is obstructed.	Clear obstructions away from inlet. Raise pump off of drum bottom.
Pump cycles unevenly or erratically.	Air motor is obstructed by ice chunks or other material.	Remove obstruction. Use dry air.
Pump dives at fast speeds only.	Fluid is too thick, causing cavitation.	Reduce viscosity of fluid by heat or dilution or slow down the pump. Raise pump off the bottom of the drum.
Air motor stalls and hisses air.	Ice has built up in the air motor.	Use dry air.
	Air motor has a broken or missing seal.	Replace air motor seals.
	Air motor has a broken part.	Replace broken item.
Air motor hisses air while running.	Air motor has a damaged o-ring or upper gasket.	Replace damaged item.
Fluid comes out of exhaust port.	Throat seals are worn or missing.	Replace throat seals.
	Air line contains too much water.	Use dry air.
Pump rod locks up.	Throat cartridge weep hole is clogged.	Clear.
Cover won't stay on.	Air motor cylinder has a leak.	Tighten air motor cylinder or cover; replace square cylinder seals.

Repair

Disconnect the Air Motor



1. Follow the **Pressure Relief Procedure**, page 8.
2. See Figure 11, page 17.
3. Release the top clamp (5).
4. Tilt the air motor and unhook the shaft from the displacement rod. Lift the air motor up and off the rest of the pump.
5. Release the bottom clamp (5). Remove connector (3) and gasket (2).
6. Remove the bung adapter clamp.
7. Pull the displacement pump straight up and out of the container.

Air Motor Disassembly

1. Use flats on the base (118) to clamp the air motor into a vise.
2. Remove the motor cover (10).
3. Remove cap (103). Use a large channel-lock or strap wrench on the cap and hold the cylinder (101) with a strap wrench to prevent distortion to the cylinder. Remove gasket (102) from inside of the cap. Inspect the spring (104) under the cap.

NOTE: Use a screwdriver to pop out the spring if it must be replaced.
4. Use a strap wrench to remove the cylinder (101). Inspect for scoring or damage.

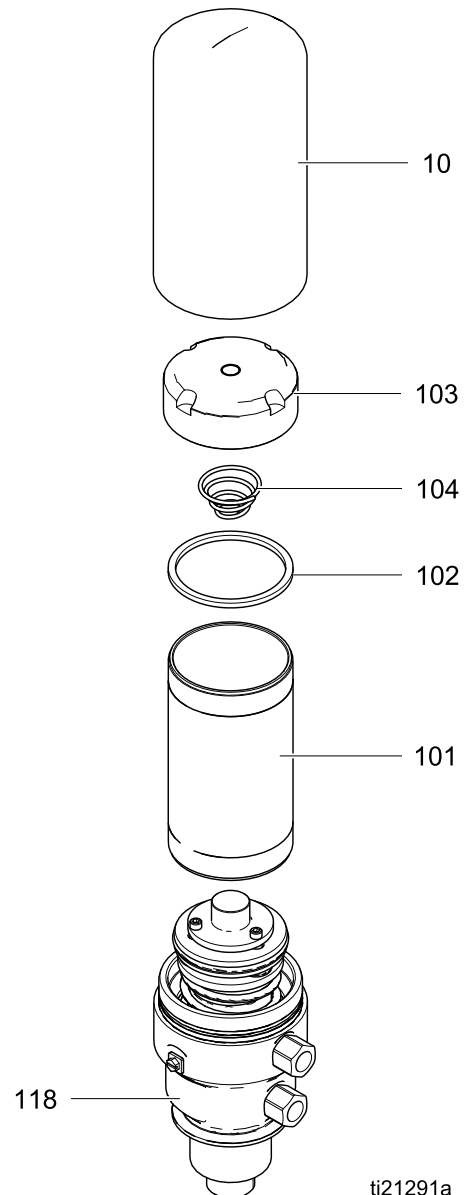

Figure 2

ti21291a



Repair

5. **Air Valve Disassembly:** Follow these steps to disassemble the air valve for cleaning or parts replacement.
- Remove three screws (114), then remove the valve cap (108). Remove gasket (107) and spacers (111).

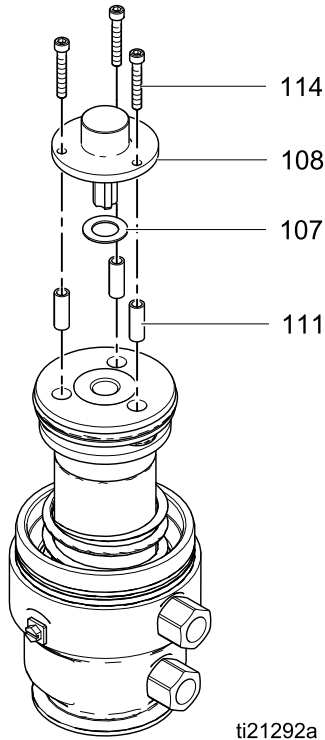

Figure 3

- Pull three o-rings (112) out the sides of the valve. Remove o-ring (106).

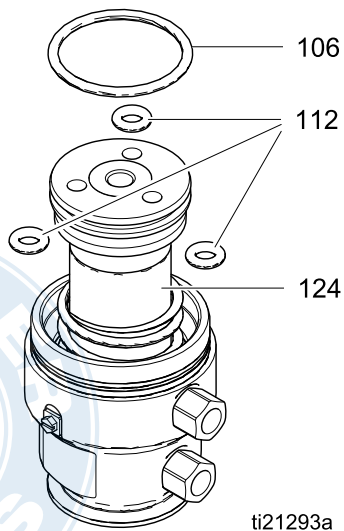

Figure 4

6. **Air Valve Replacement:** Follow these steps to replace the entire air valve, without disassembly.

- Purchase Kit 262035 to replace entire valve assembly.
- Clamp piston in a vice. Hold the piston cap with a spanner wrench and unscrew the air valve (105). Wedge a screwdriver blade between the screw heads and the hex cap of the air valve to turn.

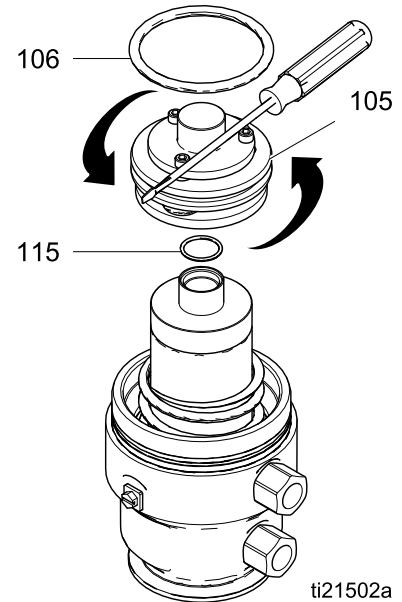

Figure 5

- Remove o-rings (115, 106).
- Replace with the new assembled valve and o-rings from Kit 262035. Use pipe sealant on the threads of the valve (105) and torque to 15 to 20 ft-lbs (20.3 to 27.1 N·m).

- Slide the air piston (124) out of the top of the air motor base (118). Remove o-ring (120) and gasket (102) from inside the air motor base. Remove o-ring (123) from groove on outside of base. Inspect all parts, including the spring (122) in the air motor base.

NOTE: Do not remove the spring (122) and retainer (121) if you do not have to.

NOTE: If the white bushing (119) needs to be replaced, use an arbor press to remove. Alternate tapping on the edges with a hammer and a nylon rod or metal punch also will work. The spring (122) and retainer (121) must be removed first.

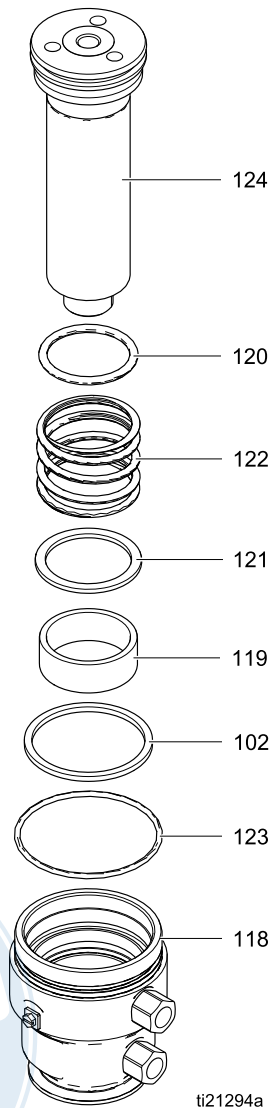
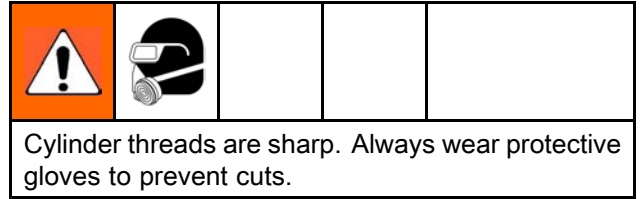
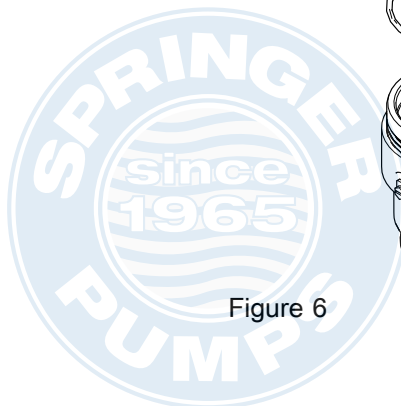

Figure 6

Air Motor Reassembly



- If the bushing (119) was removed, use an arbor press and seat it all the way into the air motor base (118). Alternate tapping using a hammer and nylon rod or metal punch also works.
- Install the retainer (121) into the air motor base. Tap on the retainer as needed to ensure it seats all the way.
- If the spring (122) was removed, put it into the air motor base (118), with the wider end down. Use a screwdriver to pop it into the groove.
- Lubricate and install o-ring (120) and gasket (102) on the inside of the motor base. Lubricate and install o-ring (123) on the outside.
- Use flats to clamp the base (118) into a vise.
- Lubricate the shoulder and the bottom outside portion of the piston (124). Then, lower it into the air motor base (118).



Repair

7. **Reassemble the air valve (if needed):** Lubricate and install a new o-ring (106) on the air valve (105). Lubricate and install the three o-rings (112), then install the spacers (111). Install gasket (107) and valve cap (108). Apply blue Loctite or equivalent on the screw threads. Torque the screws to 20 to 30 in-lb (2.3 to 3.4 N•m). Skip Step 8 and go to Step 9.

⚠ Torque to 20 to 30 in-lbs (2.3 to 3.4 N•m).

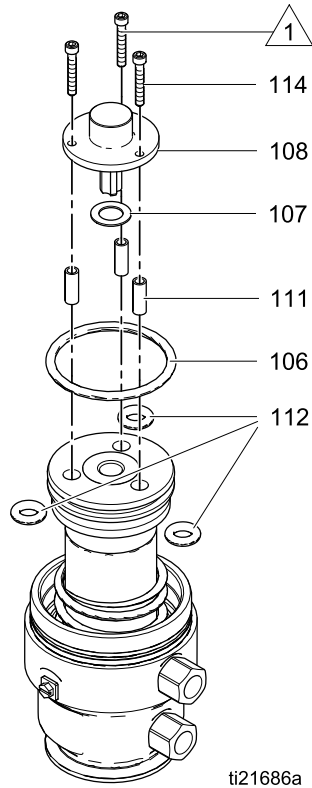

8. **Install assembled air valve from kit:** Lubricate and install new o-rings (106 and 115). Use pipe sealant on the threads of the valve (105) and torque to 15 to 20 ft-lb (20.3 to 27.1 N•m). Use a screwdriver as shown, if needed.

⚠ Torque to 15 to 20 ft-lb (20 to 27 N•m).

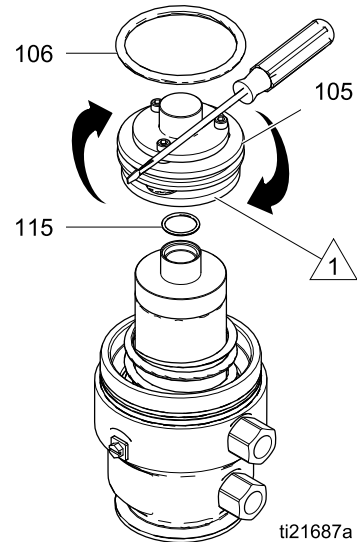

9. Grease the inside and threads of the cylinder (101). With the base clamped in a vise, put the cylinder (101) over the piston and screw into place. Tighten with a strap wrench and torque to 50 to 60 in-lb (5.6 to 6.8 N•m).
10. Lubricate and install a new gasket (102) into the air cylinder cap (103). Make sure the spring (104) is in place. Lubricate the cylinder threads. Use a strap wrench to tighten the cap (103) onto the cylinder (101). Torque to 15–20 ft-lb (20.3 to 27.1 N•m).
11. Replace the cover (10).



Disassemble the Pump

If not yet done, follow steps in [Disconnect the Air Motor, page 11](#). **Note:** Be careful not to scratch the displacement rod. Carry to the bench for service.

1. Use a pick to move the o-rings (208) to the center of the inlet seat pin (214). Slide the pin halfway out, remove the o-rings (108), then slide the pin the rest of the way out.
2. Use a screwdriver in the slot to remove the inlet valve assembly. Remove the retaining pin (212) and ball (213). Push the seat (210) out the bottom of the inlet housing (209). Remove o-rings (211 and 216). Clean and inspect the parts.

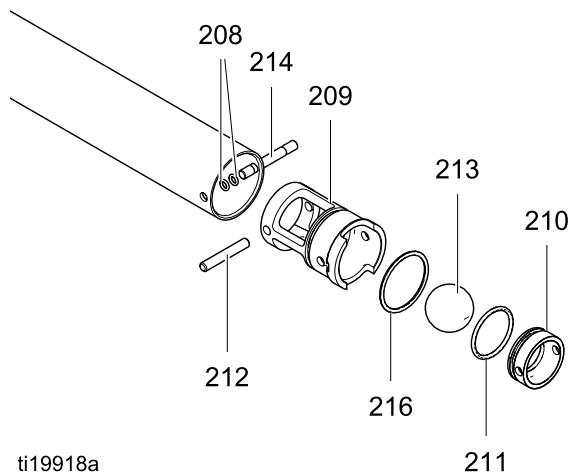

Figure 7

3. Pull the displacement rod (202) out of the top of the cylinder (201) a few inches, but do not remove

all the way. Then, remove the cartridge (215). Remove o-rings (216, 220). Use a screwdriver to push the u-cup (217) out of the center of the cartridge. Be careful not to damage the lips.

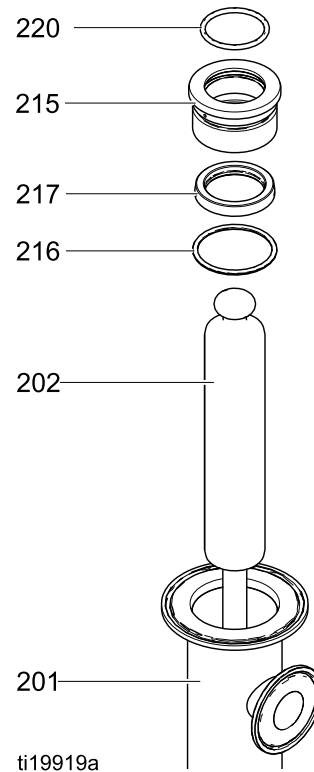
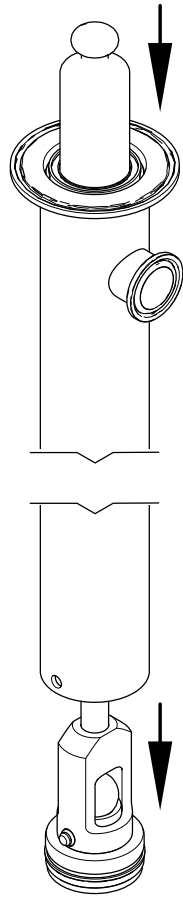

Figure 8



Repair

4. Push the displacement rod (202) all the way out the *bottom* of the cylinder.



ti19920a

Figure 9

5. See Figure 10. Remove one o-ring (208), then slide out the retaining pin (206) and remove the other o-ring. Remove the outlet assembly and ball (207). Remove the o-rings (218) from the seat (203). Be careful not to mix them up with the retaining pin o-rings (208). Slide the bearing (205) and u-cup (204) off the seat (203).

NOTE: If not replacing the u-cup (204), carefully remove and clean the o-ring, without damaging the outer or inner lip of the u-cup.

6. Clean and inspect all parts. Replace the parts as necessary.

Reassemble After Cleaning

Note: Any damaged parts **must** be replaced.

Note: Lubricate the o-rings, throat packings, and piston seals with appropriate waterproof sanitary lubricant.

1. Lubricate and install u-cup (204) and bearing (205) on the piston seat (203). U-cup lip *must face up*. Lubricate and install o-rings (218) on the seat assembly. Install the ball (207), then the seat assembly in the outlet housing.
2. Lubricate and install one o-ring (208) in the groove on the outlet seat pin (206). Push the pin (206) through the holes. Lubricate and install the other o-ring (208) in the other groove on the pin. Check that the o-rings (208) are seated in the grooves.

NOTE: Be sure to use the *smaller* o-rings (208) on the pin (206) and the *larger* o-rings (218) on the seat assembly. Stack the o-rings on the bench if needed to determine size.

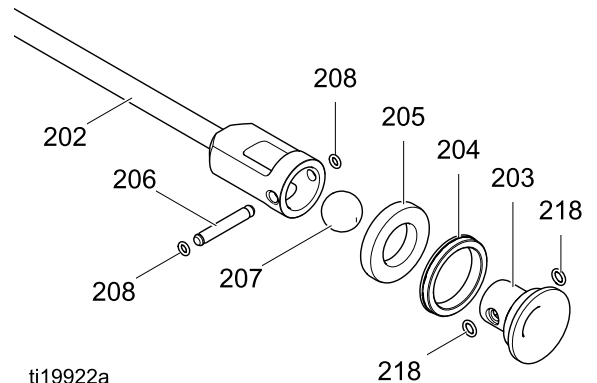

ti19922a

Figure 10

3. Lubricate the inside of the cylinder, near the ends. Then, slide the rod (202) into the cylinder *from the top*.
4. Lubricate and install a new u-cup (217) into the cartridge (215). *U-cup lips must face out of cartridge*.
5. Lubricate and install o-ring (216) on the outside of the cartridge (215).
6. Lift the rod (202) out of the cylinder part way. Lubricate the rod and slide the cartridge (215) over the rod, into the cylinder.
7. Lubricate and install o-ring (220) over the rod into the groove in the top of the cartridge. Then push the rod back into the cylinder.

8. Lubricate and install o-ring (211) on inlet seat (210), then install seat (210) in inlet housing (209). Use the pin to align the holes.
9. Lubricate and install o-ring (216) on inlet housing (209), then install the ball (213) and pin (212).
10. Slide the assembled housing into the bottom of the cylinder.
11. Push the pin (214) through the holes on one side. Lubricate and install o-rings (208) *from the inside*, putting one in each groove on the pin. Then slide the pin into the second side. The ends of the pin should be flush to the outside of the cylinder. Check that the o-rings are seated in the grooves.

Reconnect The Pump

1. If using bung adapter (Accessory Kit 24R650), install it in the drum cover.
2. Slide the displacement pump down into the drum.
3. Install a gasket (2) on the top of the displacement pump. Then install the connector (3) on the displacement pump, with the *smaller* side down. Install a clamp (5) hand tight.
4. Install the other gasket (2) on the air motor. Be sure it is securely on the alignment shoulder. Hook the air motor shaft on the displacement rod and lower the air motor into place. Install clamp (5) hand tight.

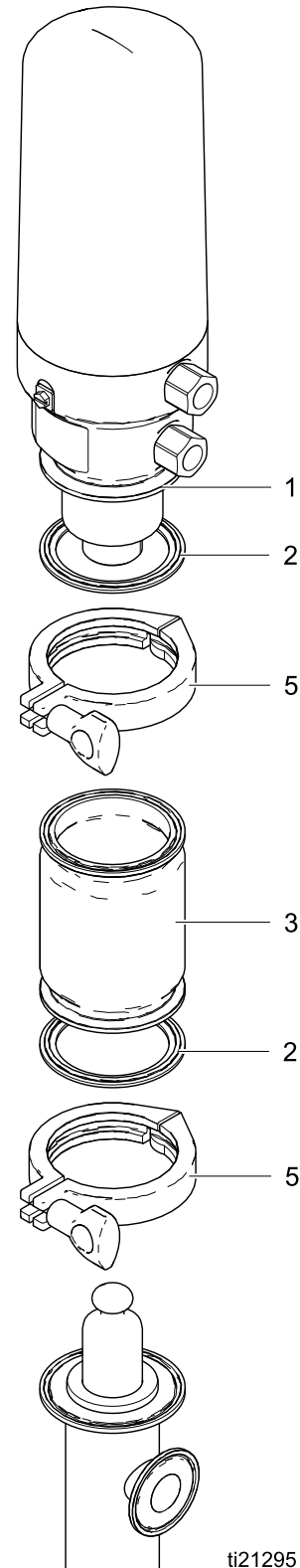

Figure 11



3A2977L

Tel: 866-777-6060
Fax: 866-777-6383

Springer Pumps, LLC

Website: www.springerpumps.com
Int'l: +001 267 404 2910

Parts

1 Apply sanitary grease before assembling cover.

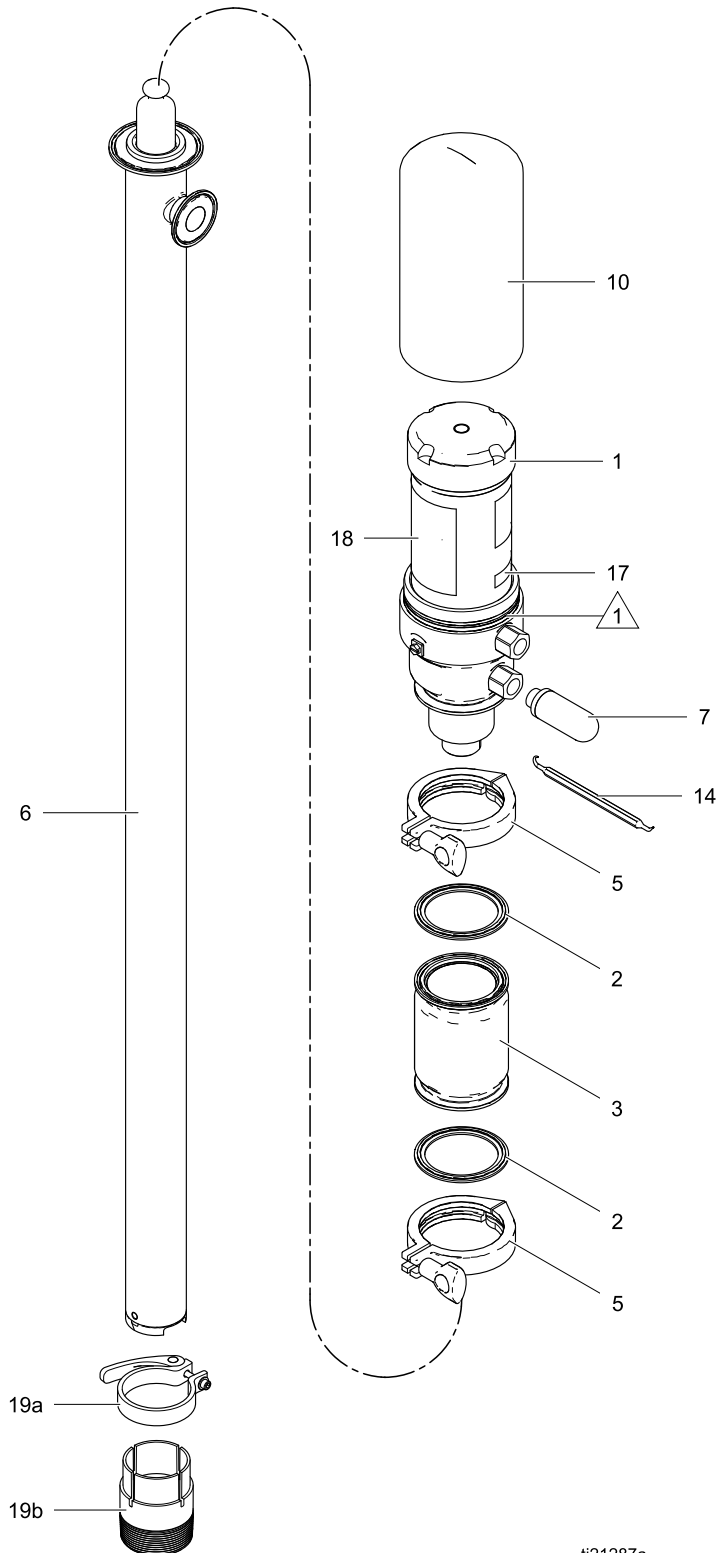

ti21287a



Complete Pump Models 24N300, 24N344, 24R046, and 24R047

Ref.	Part	Description	Qty.
1	24R180*	MOTOR, SaniForce; 2:1, see Air Motor Parts .*	1
2	166117	GASKET, sanitary fitting	2
3	16U981	CONNECTOR	1
5	620223	CLAMP, 2.5 in. Tri-clamp	2
6		DISPLACEMENT PUMP; see Displacement Pump Parts .	1
	24R190	Used on Pump Model 24N300	
	24R189	Used on Pump Model 24N344	
	24R192	Used on Pump Model 24R046	
	24R191	Used on Pump Model 24R047	
7	112933	MUFFLER	1

Ref.	Part	Description	Qty.
10	24R178	COVER, motor; includes o-ring (ref. 123)	1
14	16U653	TOOL, pick	1
17	— — —	LABEL, compliance	1
18▲	16T148	LABEL, warning	1
19	24R650	KIT, bung adapter, includes 19a and 19b	1
19a	— — —	Clamp	
19b	— — —	Bung adapter	

▲ Replacement Danger and Warning labels, tags, and cards are available at no cost.

* Air Motor 24R180 does not include cover (ref. 10). Order Kit 24R179 for an air motor with cover.



Air Motor 24R180

- 1 Torque to 50 to 60 in-lb (5.6 to 6.8 N•m).
- 2 Apply sanitary lubricant.
- 3 Apply medium-strength thread locker.
- 4 Torque to 15 to 20 ft-lb (20.3 to 27.1 N•m).
- 5 Torque to 20 to 30 in-lb (2.3 to 3.4 N•m).
- 6 Apply pipe sealant.

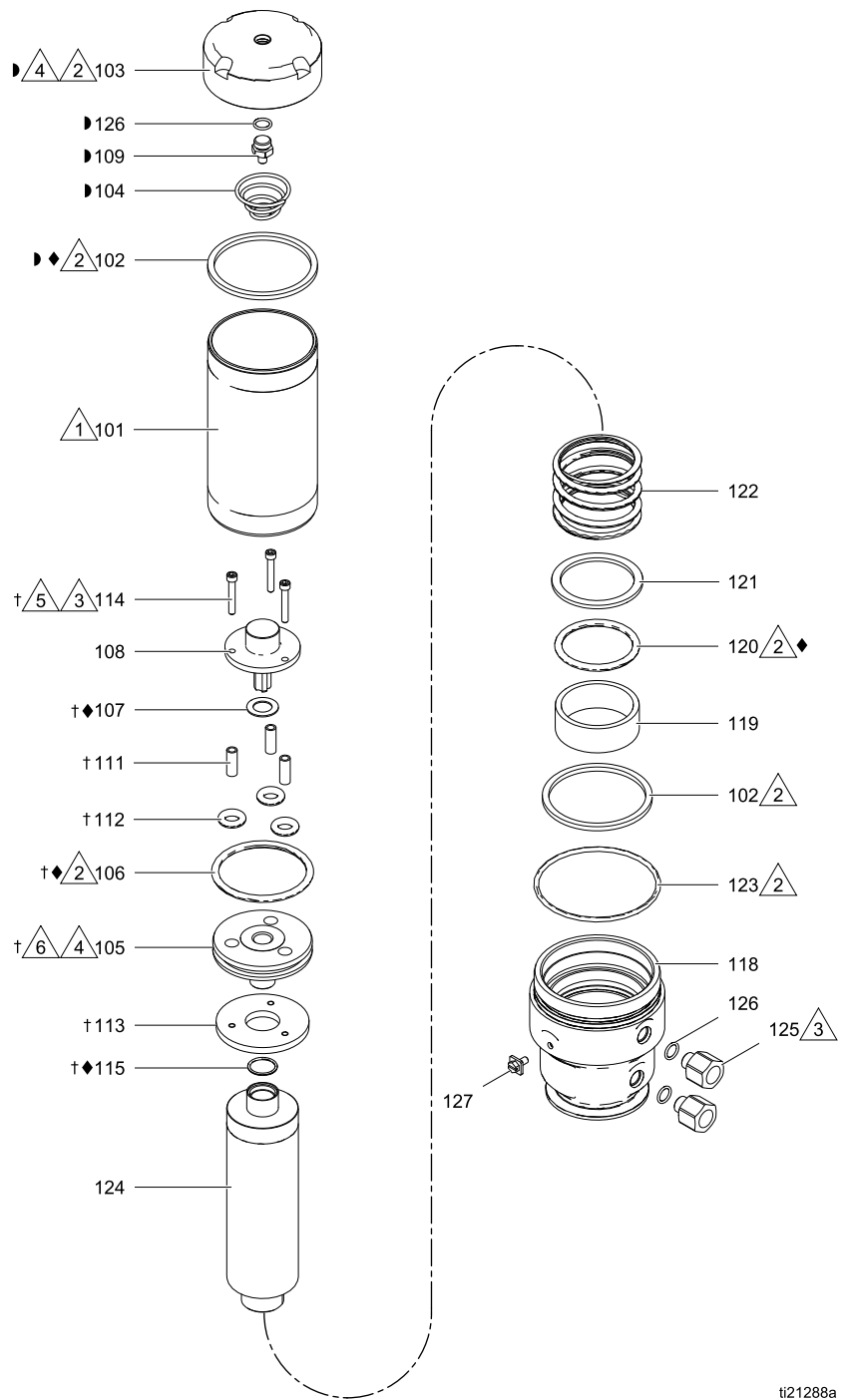

Air Motor 24R180 Parts

Ref.	Part	Description	Qty.
101	16P288	CYLINDER, air motor	1
102◆▶	120212	GASKET	2
103▶	— — —	CAP, air cylinder	1
104▶	157630	SPRING, tapered	1
105†	— — —	HEAD, air piston	1
106◆†	160258	O-RING, buna-N	1
107◆†	— — —	GASKET, upper	1
108†	— — —	CAP, valve	1
109▶	— — —	PIN, spring stop; included with ref. 103	1
111†	15J544	SPACER, disk	3
112†	— — —	O-RING, buna-N	3
113†	15J546	DISK, air piston	1
114†	121610	SCREW, cap, socket head	3
115◆†	722834	O-RING, FKM	1
118	16P900	BASE, air motor	1
119	- - -	BUSHING, air motor; included with air piston assembly (ref. 124)	1

Ref.	Part	Description	Qty.
120◆	159846	O-RING, buna-N	1
121	16P926	RETAINER, o-ring	1
122	15J551	SPRING, compression	1
123	U22665	O-RING	1
124	24R176	PISTON, air, assembly; includes Bushing (ref. 119) and o-ring (ref. 120)	1
125	24R177	FITTING, inlet/outlet, stainless steel, 1/2-18 to 3/8-18 npt; includes o-ring (ref. 126)	2
126▶	111819	O-RING; included with ref. 103	3
127	116343	SCREW, ground	1

- ◆ Parts included in Air Motor Seal Kit 24R175.
- † Parts included in Air Valve Kit 262035.
- ▶ Parts included in Air Cylinder Cap Kit 24T043.



Displacement Pump Models 24R189, 24R190, 24R191, and 24R192

 Apply sanitary lubricant.

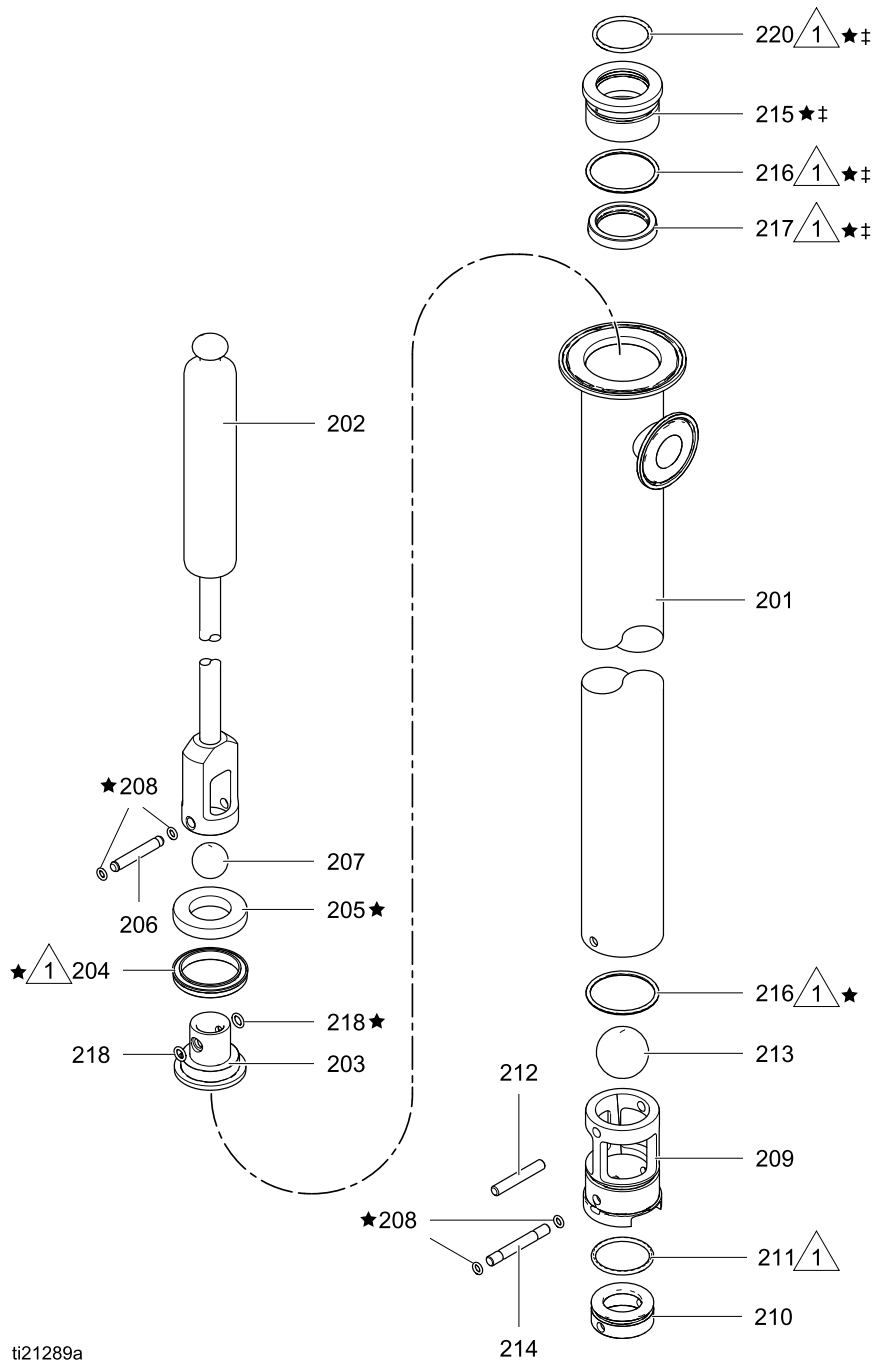

ti21289a



Displacement Pump Parts

Ref.	Part	Description	Qty.
201		CYLINDER, pump	1
	24R193	Models 24R190 and 24R189	
	24R194	Models 24R192 and 24R191	
202		ROD, displacement	1
	24R183	Models 24R190 and 24R189	
	24R184	Models 24R192 and 24R191	
203	16P149	SEAT, outlet; sold with ball (ref. 207) in Kit 24R181	1
204*		U-CUP	1
	16P254	UHMWPE; Models 24R190 and 24R192	
	16P044	PTFE; Models 24R189 and 24R191	
205*	16P150	BEARING, piston check	1
206	16P147	PIN, outlet check; order Kit 24R195	1
207	104585	BALL, stainless steel; sold with seat (ref. 203) in Kit 24R181.	1
208*	— — —	O-RING, 008, FKM; included in Kits 24R187, 24R188, 24R195 and 24R196	10
209	17A630	GUIDE, ball, inlet, 316 stainless steel	1
210	16P132	SEAT, inlet; sold with ball (ref. 213) and o-ring (ref. 211) in Kit 24R182	1

Ref.	Part	Description	Qty.
211*	— — —	O-RING, 125, FKM; sold with seat (ref. 210) and ball (ref. 213) in Kit 24R182	1
212	126216	PIN, dowel	1
213	103869	BALL, bearing	1
214	16P146	PIN, seat, inlet; order Kit 24R195	1
215*✓	16P242	CARTRIDGE, throat seal	1
216*✓	— — —	O-RING, 129, FKM	2
217*✓	— — —	U-CUP	1
	16P255	UHMWPE; Models 24R190 and 24R192	
	16P041	PTFE; Models 24R189 and 24R191	
218*	— — —	O-RING, FKM, #10; included in Kits 24R187, 24R188, 24R195 and 24R196	2
220*✓	— — —	O-RING	1
	126806	FKM; Models 24R190 and 24R192	
	124494	PTFE; Models 24R189 and 24R191	

* Parts included in Pump Seals Kits 24R187 (UHMWPE) and 24R188 (PTFE).

✓ Parts included in Throat Seal Kits 24R185 (UHMWPE) and 24R186 (PTFE).



Kits and Accessories

Replacement Parts Kits

Kit	Includes
◆ 24R175, Air Motor Seals	Gasket (102), o-rings (106, 115, 120), and upper gasket (107)
† 262035, Air Valve Kit	Piston head (105), upper gasket (107), valve cap (108), spacer (111), piston disk (113), screws (114), and o-rings (106, 112, 115)
* 24R187, UHMWPE Pump Seals Kit OR 24R188, PTFE Pump Seals Kit	Piston check bearing (205), u-cup cartridge (215), u-cups (214, 217), and o-rings (208, 211, 216, 218, 220)
✓ 24R185, UHMWPE Throat Seal Kit OR 24R186, PTFE Throat Seal Kit	U-cup cartridge (215), u-cup (217), and o-rings (216, 220)
▶ 24T043, Air Cylinder Cap Kit	Cap (103), gasket (102), spring (104), pin (109), and o-ring (126)
24R176, Air Motor Piston Kit	Piston with cap and o-ring (124, factory assembled), bushing (119) and o-ring (120)
24R177, Air Inlet/Outlet Fitting Kit	Inlet/outlet fitting (125) and o-ring (126)
24R178, Air Motor Cover Kit	Cover (10) and o-ring (123)
24R179, Air Motor with Cover Kit	Air motor 24R180 (1) and cover (10)
24R181, Outlet Check	Seat (203) and ball (207)
24R182, Inlet Check	Seat (210), ball (213), and o-ring (211)
24V838, Inlet Ball Guide Kit	Guide (209) and o-ring (216)
24R195, Retainer Pins	Inlet pin (214), piston pin (206) and o-rings (208, 218)
24R196, Retainer Pin O-rings	O-ring (208, qty. 20) and o-ring (218, qty. 10)

Accessory Kits

Kit	Description
24R646, Exhaust Hose	3/8 npt, 200 psi, FDA-Compliant hose, 6 ft.
24R649, ISO/DIN Adapter	1 in. (25 mm) Tri-clamp to 25 mm threaded DIN 11851, with o-ring

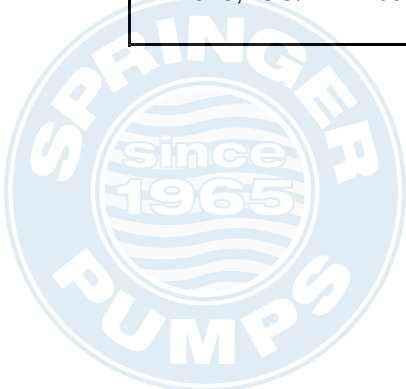

Dimensions

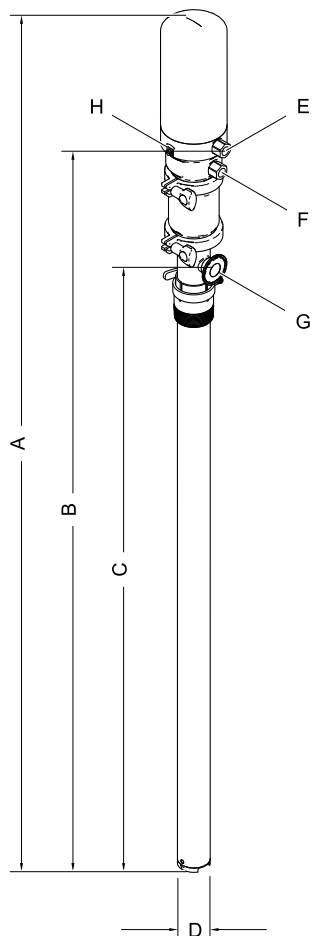

ti19925a

Reference	Model 24N300 and 24N344		Model 24R046 and 24R047	
	in.	cm	in.	cm
A	61.9	157.2	54.9	139.4
B	53.7	136.4	46.7	118.6
C	44.5	113.0	37.5	95.2
D (fluid inlet OD)	1.972	5.0	1.972	5.0
E (air inlet)	3/8 npt (f)	9.5 npt (f)	3/8 npt (f)	9.5 npt (f)
F (air exhaust)	3/8 npt (m)	9.5 npt (m)	3/8 npt (m)	9.5 npt (m)
G (fluid outlet, Tri-Clamp)	1	2.5	1	2.5
H (ground screw)				

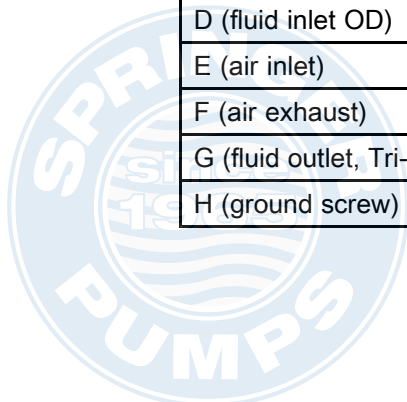

Performance Chart

Test Conditions: Pump tested in water.

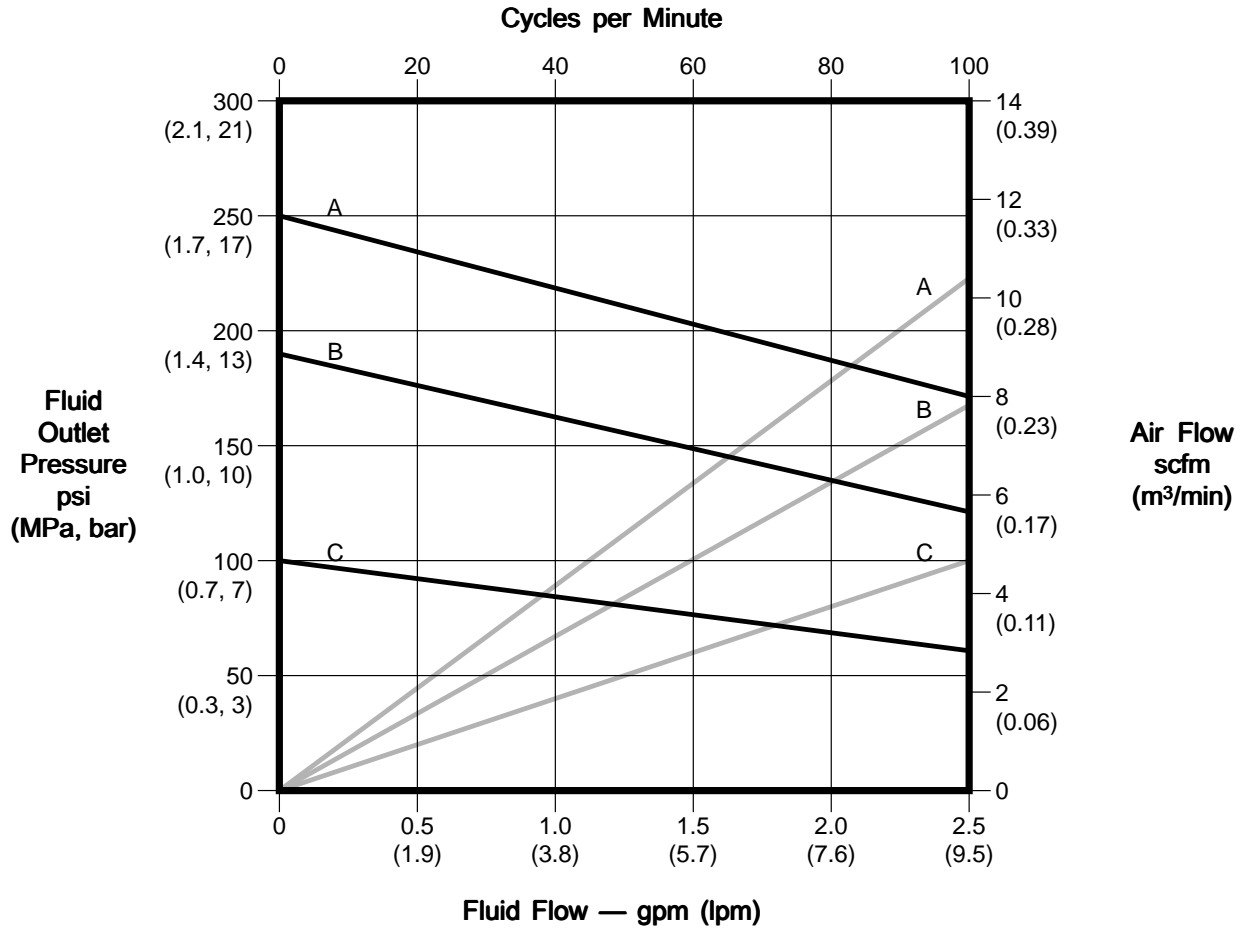

KEY:

- A 100 psi (0.7 MPa, 7 bar) Inlet Air Pressure
- B 70 psi (0.5 MPa, 5 bar) Inlet Air Pressure
- C 40 psi (0.3 MPa, 3 bar) Inlet Air Pressure
- Air Consumption
- Fluid Flow



Technical Data

	U.S.	Metric
Maximum Fluid Working Pressure	250 psi	17 bar, 1.7 MPa
Air Inlet Pressure Range	30 to 100 psi	2.1 to 6.9 bar, 0.2 to 0.7 MPa
Maximum Recommended Pump Speed	100 cycles/min, 2.5 gpm delivery	100 cycles/min, 9.5 liters/min delivery
Pump Cycles per Gallon (3.8 Liters)	40	
Ratio	2.5:1	
Fluid Temperature Range	40 to 220°F	4 to 104°C
Maximum Continuous Operating Temperature	180°F	82°C
Maximum Ambient Temperature (Air Motor)	120°F	49°C
Maximum size pumpable solids	1/8 in.	3.2 mm
Air Inlet	3/8 npt (f)	9.5 mm npt (f)
Air Exhaust	3/8 npt (m)	9.5 mm npt (m)
Fluid Inlet Size		
Cylinder OD	2.0 in	5 cm
Inlet Seat ID	0.938 in	2.4 cm
Fluid Outlet	1 in. Tri-clamp®	2.5 cm Tri-clamp®
Sound Power*	73.4 at dBA at 70 psi and 20 cpm	73.4 dBA at 4.8 bar and 20 cpm
Sound Pressure*	65.4 at dBA at 70 psi and 20 cpm	65.4 dBA at 4.8 bar and 20 cpm
Weight		
Models 24R046 and 24R047	24 lb	10.9 kg
Models 24N300 and 24N344	26 lb	11.8 kg
Wetted Parts	300 Series Stainless Steel, Acetal, PTFE, FKM, UHMWPE	
* Sound power measured per ISO-9614-2. Sound pressure was tested 3.28 ft (1 m) from equipment.		

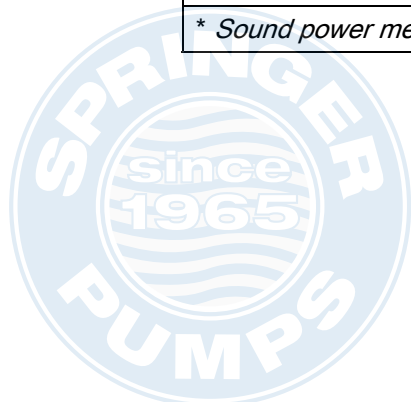

Graco Standard Warranty

Graco warrants all equipment referenced in this document which is manufactured by Graco and bearing its name to be free from defects in material and workmanship on the date of sale to the original purchaser for use. With the exception of any special, extended, or limited warranty published by Graco, Graco will, for a period of twelve months from the date of sale, repair or replace any part of the equipment determined by Graco to be defective. This warranty applies only when the equipment is installed, operated and maintained in accordance with Graco's written recommendations.

This warranty does not cover, and Graco shall not be liable for general wear and tear, or any malfunction, damage or wear caused by faulty installation, misapplication, abrasion, corrosion, inadequate or improper maintenance, negligence, accident, tampering, or substitution of non-Graco component parts. Nor shall Graco be liable for malfunction, damage or wear caused by the incompatibility of Graco equipment with structures, accessories, equipment or materials not supplied by Graco, or the improper design, manufacture, installation, operation or maintenance of structures, accessories, equipment or materials not supplied by Graco.

This warranty is conditioned upon the prepaid return of the equipment claimed to be defective to an authorized Graco distributor for verification of the claimed defect. If the claimed defect is verified, Graco will repair or replace free of charge any defective parts. The equipment will be returned to the original purchaser transportation prepaid. If inspection of the equipment does not disclose any defect in material or workmanship, repairs will be made at a reasonable charge, which charges may include the costs of parts, labor, and transportation.

THIS WARRANTY IS EXCLUSIVE, AND IS IN LIEU OF ANY OTHER WARRANTIES, EXPRESS OR IMPLIED, INCLUDING BUT NOT LIMITED TO WARRANTY OF MERCHANTABILITY OR WARRANTY OF FITNESS FOR A PARTICULAR PURPOSE.

Graco's sole obligation and buyer's sole remedy for any breach of warranty shall be as set forth above. The buyer agrees that no other remedy (including, but not limited to, incidental or consequential damages for lost profits, lost sales, injury to person or property, or any other incidental or consequential loss) shall be available. Any action for breach of warranty must be brought within two (2) years of the date of sale.

GRACO MAKES NO WARRANTY, AND DISCLAIMS ALL IMPLIED WARRANTIES OF MERCHANTABILITY AND FITNESS FOR A PARTICULAR PURPOSE, IN CONNECTION WITH ACCESSORIES, EQUIPMENT, MATERIALS OR COMPONENTS SOLD BUT NOT MANUFACTURED BY GRACO. These items sold, but not manufactured by Graco (such as electric motors, switches, hose, etc.), are subject to the warranty, if any, of their manufacturer. Graco will provide purchaser with reasonable assistance in making any claim for breach of these warranties.

In no event will Graco be liable for indirect, incidental, special or consequential damages resulting from Graco supplying equipment hereunder, or the furnishing, performance, or use of any products or other goods sold hereto, whether due to a breach of contract, breach of warranty, the negligence of Graco, or otherwise.

FOR GRACO CANADA CUSTOMERS

The Parties acknowledge that they have required that the present document, as well as all documents, notices and legal proceedings entered into, given or instituted pursuant hereto or relating directly or indirectly hereto, be drawn up in English. Les parties reconnaissent avoir convenu que la rédaction du présente document sera en Anglais, ainsi que tous documents, avis et procédures judiciaires exécutés, donnés ou intentés, à la suite de ou en rapport, directement ou indirectement, avec les procédures concernées.

Graco Information

For the latest information about Graco products, visit www.graco.com.
For patent information, see www.graco.com/patents.

To place an order, contact your Graco Distributor or call to identify the nearest distributor.

Phone: 612-623-6921 **or Toll Free:** 1-800-328-0211 **Fax:** 612-378-3505

All written and visual data contained in this document reflects the latest product information available at the time of publication.

Graco reserves the right to make changes at any time without notice.
Original Instructions. This manual contains English. MM 3A2977

Graco Headquarters: Minneapolis
International Offices: Belgium, China, Japan, Korea

GRACO INC. AND SUBSIDIARIES • P.O. BOX 1441 • MINNEAPOLIS MN 55440-1441 • USA
Copyright 2013, Graco Inc. All Graco manufacturing locations are registered to ISO 9001.

www.graco.com
Revision L, October 2019