

SaniForce™ 6:1 Sanitary Pumps

3A0733P
EN

For use in sanitary applications to transfer medium to high viscosity fluids. For professional use only.



Important Safety Instructions

Read all warnings and instructions in this manual. Save these instructions.

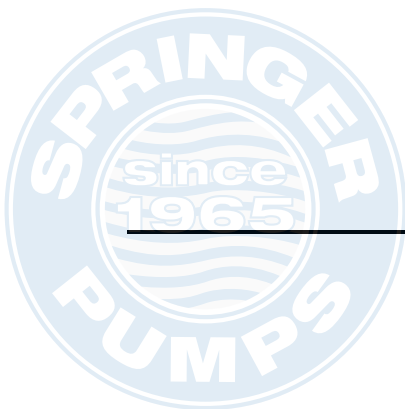
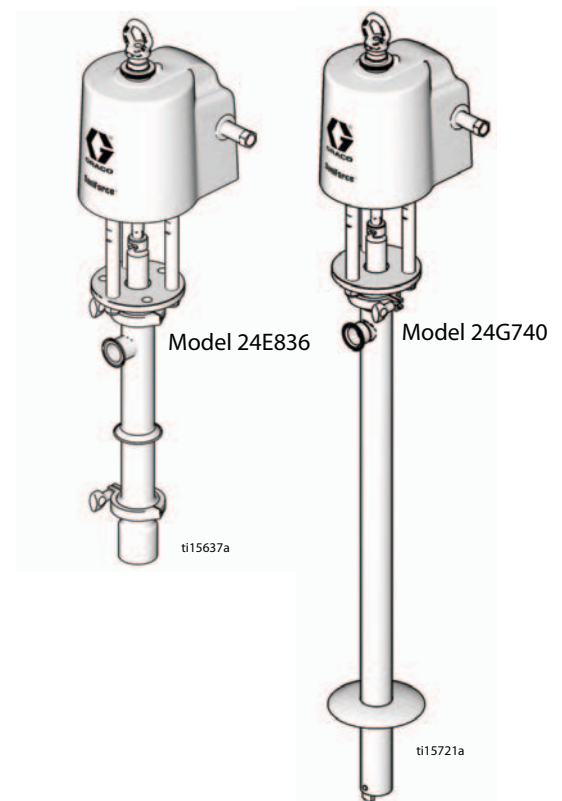

PROVEN QUALITY. LEADING TECHNOLOGY.

Contents

Models.....	3	Reassemble After Cleaning	12
Warnings	4	Double Ball Service	13
.....	4	Disconnect the Pump	13
Installation.....	6	Disassemble the Pump.....	14
Grounding	6	Reassemble After Cleaning	14
Mounting	6	Parts.....	15
Setup	6	Kits.....	16
Operation.....	8	Priming Piston Displacement Pump Models	
Pressure Relief Procedure.....	8	24G747 and 24G746	17
Flush Before First Use.....	8	Double ball Displacement Pump Models	
Adjusting the Pump Speed and		24G748, 24G749, 24G753, 24G750,	
Pressure	8	and 26A158	19
Pump Shut Down.....	8	Double-Ball Displacement Pump Models	
Maintenance	9	24G752 and 24G751	21
Flushing Procedure	9	Product Dimensions.....	23
Cleaning.....	9	Performance chart	24
Tighten Threaded Connections	9	Technical Data	25
Troubleshooting.....	10	Graco Standard Warranty.....	26
Priming Piston Service	11		
Disconnect the Pump	11		
Disassemble the Pump.....	11		



Models

Maximum Air Inlet Pressure: 100 psi (0.7 MPa, 6.9 bar)

Maximum Fluid Working Pressure: 650 psi (4.5 MPa, 44.8 bar)

Pump Model	Pump Lower Replacement	Pump Type	Pump Length Description	Packings
24E836	24G746	Priming Piston	Stubby	Buna-N, Nitrile, Nylon, and Polychloroprene
24E837	24G751	Double Ball	Stubby	PTFE
24E838	24G752	Double Ball	Stubby	Buna-N, Polychloroprene, and UHMWPE
24E839	24G753	Double Ball	Drum Length	PTFE
24E840	24G749	Double Ball	Drum Length	Buna-N, Nitrile, Nylon, and Polychloroprene
24F942	24G750	Double Ball	Bin Length	Buna-N, Nitrile, Nylon, and Polychloroprene
24G739	24G747	Priming Piston	Stubby, with Flange	Buna-N, Nitrile, Nylon, and Polychloroprene
24G740	24G748	Double Ball	Drum Length, with Flange	Buna-N, Nitrile, Nylon, and Polychloroprene
25A936	26A158	Double Ball	Bin Length	PTFE
 All models are compliant with:				

EC 1935/2004 compliant pumps may be subject to individual national provisions in addition to those specified in the EC regulation. It is the users responsibility to know and follow local laws.



3A0733P





Tel: 866-777-6060
Fax: 866-777-6383

Springer Pumps, LLC

Website: www.springerpumps.com
Int'l: +001 267 404 2910

Warnings

The following warnings are for the setup, use, grounding, maintenance and repair of this equipment. The exclamation point symbol alerts you to a general warning and the hazard symbol refers to procedure-specific risks. When these symbols appear in the body of this manual refer back to these Warnings. Product-specific hazard symbols and warnings not covered in this section may appear throughout the body of this manual where applicable.

 <h2 style="margin: 0;">WARNING</h2>	
	<p>SKIN INJECTION HAZARD</p> <p>High-pressure fluid from dispensing device, hose leaks, or ruptured components will pierce skin. This may look like just a cut, but it is a serious injury that can result in amputation. Get immediate surgical treatment.</p> <ul style="list-style-type: none"> • Do not point dispensing device at anyone or at any part of the body. • Do not put your hand over the fluid outlet. • Do not stop or deflect leaks with your hand, body, glove, or rag. • Follow the Pressure Relief Procedure when you stop dispensing and before cleaning, checking, or servicing equipment. • Tighten all fluid connections before operating the equipment. • Check hoses and couplings daily. Replace work or damaged parts immediately.
	<p>MOVING PARTS HAZARD</p> <p>Moving parts can pinch, cut or amputate fingers and other body parts.</p> <ul style="list-style-type: none"> • Keep clear of moving parts. • Do not operate equipment with protective guards or covers removed. • Pressurized equipment can start without warning. Before checking, moving, or servicing equipment, follow the Pressure Relief Procedure and disconnect all power sources.
	<p>FIRE AND EXPLOSION HAZARD</p> <p>Flammable fumes, such as solvent and paint fumes, in work area can ignite or explode. To help prevent fire and explosion:</p> <ul style="list-style-type: none"> • Use equipment only in well ventilated area. • Eliminate all ignition sources; such as pilot lights, cigarettes, portable electric lamps, and plastic drop cloths (potential static arc). • Keep work area free of debris, including solvent, rags and gasoline. • Do not plug or unplug power cords, or turn light switches on or off when flammable fumes are present. • Ground all equipment in the work area. See Grounding instructions. • Use Only grounded hoses. • Hold gun firmly to side of grounded pail when triggering into pail. • If there is static sparking or you feel a shock, stop operation immediately. Do not use equipment until you identify and correct the problem. • Keep a working fire extinguisher in the work area.



WARNING



EQUIPMENT MISUSE HAZARD

Misuse can cause death or serious injury.

- Do not operate the unit when fatigued or under the influence of drugs or alcohol.
- Do not exceed the maximum working pressure or temperature rating of the lowest rated system component. See **Technical Data** in all equipment manuals.
- Use fluids and solvents that are compatible with equipment wetted parts. See **Technical Data** in all equipment manuals. Read fluid and solvent manufacturer's warnings. For complete information about your material, request MSDS from distributor or retailer.
- Do not leave the work area while equipment is energized or under pressure. Turn off all equipment and follow the **Pressure Relief Procedure** when equipment is not in use.
- Check equipment daily. Repair or replace worn or damaged parts immediately with genuine manufacturer's replacement parts only.
- Do not alter or modify equipment.
- Use equipment only for its intended purpose. Call your distributor for information.
- Route hoses and cables away from traffic areas, sharp edges, moving parts, and hot surfaces.
- Do not kink or over bend hoses or use hoses to pull equipment.
- Keep children and animals away from work area.
- Comply with all applicable safety regulations.



SPLATTER HAZARD

Hot or toxic fluid can cause serious injury if splashed in the eyes or on skin. During blow off of platen, splatter may occur.

- Use minimum air pressure when removing platen from drum.



TOXIC FLUID OR FUMES

Toxic fluids or fumes can cause serious injury or death if splashed in the eyes or on skin, inhaled, or swallowed.

- Read MSDSs to know the specific hazards of the fluids you are using.
- Store hazardous fluid in approved containers, and dispose of it according to applicable guidelines.



PERSONAL PROTECTIVE EQUIPMENT

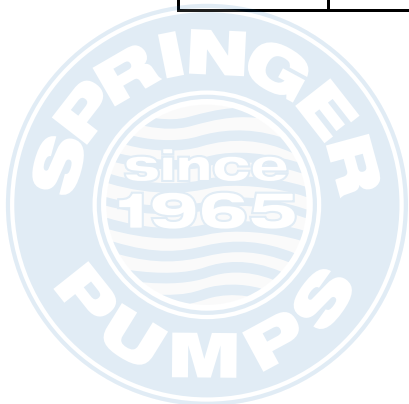

You must wear appropriate protective equipment when operating, servicing, or when in the operating area of the equipment to help protect you from serious injury, including eye injury, hearing loss, inhalation of toxic fumes, and burns. This equipment includes but is not limited to:

- Protective eyewear, and hearing protection.
- Respirators, protective clothing, and gloves as recommended by the fluid and solvent manufacturer.



Installation

Grounding

				
<p>The equipment must be grounded. Grounding reduces the risk of static and electric shock by providing an escape wire for the electrical current due to static build up or in the event of a short circuit.</p>				

Pump: Connect a ground wire (Graco PN 238909) to the ground screw on the bottom cover of the air motor, under the shield. Connect the other end of the ground wire to a true earth ground.

Air and fluid hoses: use only electrically conductive hoses with a maximum of 500 ft. (150 m) combined hose length to ensure grounding continuity. Check electrical resistance of hoses. If total resistance to ground exceeds 25 megohms, replace hose immediately.

Air compressors: follow manufacturer's recommendations.

Dispense valve: ground through connection to a properly grounded fluid hose and pump.

Material supply container: follow local code.

Container(s) that receive material: follow local code.



Solvent pails used when flushing: follow local code. Use only conductive metal pails, placed on a grounded surface. Do not place the pail on a nonconductive surface, such as paper or cardboard, which interrupts grounding continuity.

To maintain grounding continuity when flushing or relieving pressure: hold metal part of the dispense valve firmly to the side of a grounded metal pail, then trigger the valve.





Mounting

Mount the pump on a surface than can support the weight of the pump and accessories, as well as the stress caused during operation. Do not use air or fluid lines to support the pump.

				
<p>To avoid serious injury, check the torque on the lift ring (19) and nut (18) before using the lift ring to lift the pump. Torque to 30–36 ft-lb (41–49 N•m).</p>				

Setup

				
<p>To avoid contaminating the fluid, pipe the exhaust air to vent outside of the fluid product area, away from people, animals, or food handling areas.</p>				

Note

Reference numbers and letters in parentheses in the text refer to the callouts in the figures and the parts drawings.

Accessories are available from Graco. Make certain all accessories are sized and pressure rated to meet your system requirements.

Fig 1 is only a guide for selecting and installing system components and accessories. Contact your Graco distributor for assistance in designing a system to suit your particular needs.

Install a bleed-type master air valve (G) close to the pump air inlet (D), to relieve air trapped between it and the air motor.

Install an air filter/regulator (F) in the pump air line, *upstream from the bleed valve*, to control air inlet pressure and to remove harmful dirt and contaminants from your compressed air supply.

Install a pump runaway valve (S) in the pump air line to shut off air to the air motor automatically if the pump starts to run too fast.

Install another bleed-type master air valve (G) upstream from all air line accessories and use it to isolate the accessories during cleaning and repair.

On the air drop to the dispense valve (K), install an air regulator (M) to control air pressure to the valve. Install a bleed valve (G) to use as a shutoff when servicing the dispense valve.

Connect air solenoid valves (H) to a timer control (L), and set so the dispense valve (K) will dispense at proper intervals.

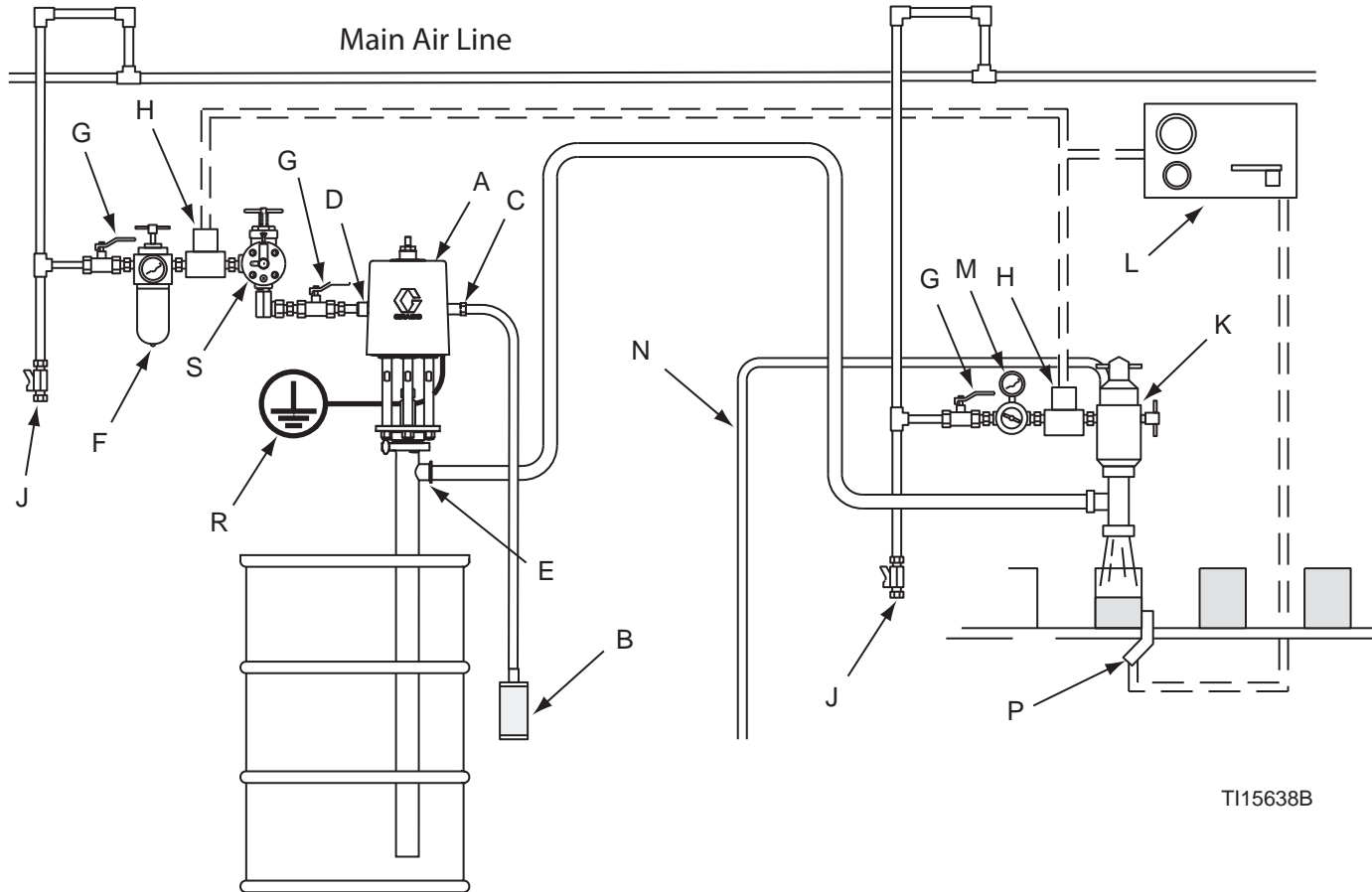

T115638B

Figure 1 Typical Installation

Key

Pump Components (Included)

- A Bung-Mounted Sanitary Pump
- B Air Exhaust Muffler (may alternately be mounted remotely, using exhaust hose)
- C 3/4 npt Exhaust Air Outlet
- D 1/2 npt Air Inlet
- E 1-1/2 in. Tube Size Flanged Fluid Outlet

System Components/Accessories (sold separately)

- F Air Line Filter/Regulator
- G Bleed-Type Master Air Valve (required)
- H Air Solenoid Valve
- J Air Line Drain Pipe and Valve
- K Dispensing Valve
- L Timer Control
- M Air Regulator
- N Dispensing Valve Air Exhaust Hose
- P Sensing Device
- R Pump Ground Wire (required)
- S Pump Runaway Valve

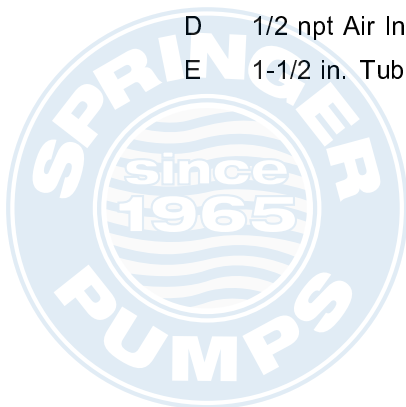

3A0733P

Tel: 866-777-6060

Fax: 866-777-6383

Springer Pumps, LLC

Website: www.springerpumps.com

Int'l: +001 267 404 2910

Operation

NOTICE

Do not expose the air motor to temperatures higher than 120°F (49°C) or the immersed fluid pump to temperatures higher than 250°F (121°C). Excessive temperatures may damage the pump packings and seals

Pressure Relief Procedure



Trapped air can cause the pump to cycle unexpectedly, which could result in serious injury from injection, splashing or moving parts. Relieve pressure when you stop pumping and before cleaning, checking, or servicing equipment.

1. Shut off the air supply to the pump.
2. Close the bleed-type master air valve (required in system).
3. Open the fluid ball valve and/or dispensing valve to relieve fluid pressure.

Flush Before First Use

The sanitary pump was assembled using sanitary lubricant on moving parts and was tested in water. Flush the pump thoroughly with an appropriate cleaning solution or disassemble and sanitize the parts before using the pump. See

[Flushing Procedure, page 9](#) . Check national, state, and local codes for specific limitations.

Adjusting the Pump Speed and Pressure

Set pressure regulator to 0 psi. Open the bleed-type master air valve. Adjust the pump air regulator until the pump is running smoothly.

Allow the pump to cycle slowly until all air is pushed out of the lines (the fluid will flow in a steady stream from the fluid outlet) and the pump is primed.

With the air supply turned on, the pump will start when the dispensing valve is opened and stall against pressure when the valve is closed. In a circulating system, the pump operates until the air supply is turned off.

NOTICE

Never allow the pump to run dry of fluid. A dry pump will accelerate to a high speed, possibly damaging itself.

If the pump accelerates quickly, or is running too fast, stop the pump immediately and check the fluid supply. If the supply is empty and air has been pumped into the lines, refill the container and prime the pump and lines with fluid. Be sure to eliminate all air from the system.

Pump Shut Down

Follow the [Pressure Relief Procedure, page 8](#) . Always stop the pump at the bottom of its stroke to prevent fluid from drying on the displacement rod. (The air motor will exhaust at the bottom or top of the stroke.)



Maintenance

Flushing Procedure



Note:

- Flush before fluid can dry in the equipment, at the end of the day, before storing, and before repairing equipment.
 - Flush at the lowest pressure possible. Check connectors for leaks and tighten as necessary.
 - Flush with an appropriate cleaning solution.
1. Remove the pump from the fluid container. Operate it to pump out as much fluid as possible.
 2. Follow the [Pressure Relief Procedure, page 8](#).
 3. Place siphon tube in grounded metal pail containing an appropriate cleaning solution.
 4. Set pump air regulator to lowest possible fluid pressure, and start pump.
 5. Run the pump long enough to thoroughly clean the pump and hoses.
 6. Follow the [Pressure Relief Procedure, page 8](#).

Cleaning

- **Be sure** to follow your national and state sanitary standard codes and local regulations.
- Use appropriate cleaning and disinfecting agents, at intervals appropriate for product processed.
- Follow cleaning product manufacturer's instructions.

Note: The pump **must be disassembled** to thoroughly clean it.

1. Remove the pump from the fluid container. Operate it to pump out as much fluid as possible.
2. Flush the system thoroughly with an appropriate cleaning solution. See [Flushing Procedure, page 9](#).

3. Follow the [Pressure Relief Procedure, page 8](#).
4. Remove the air and fluid hoses and fittings from the pump.
5. **Ram-Mounted Pumps:** Loosen the hand screw and lift the upper shield straight up on the rod. **Other Pumps:** Remove the upper shield.
6. Clean thoroughly the surface between the upper and lower shields.
7. Disassemble the fluid pump and accessories. See [Priming Piston Service, page 11](#) or [Double Ball Service, page 13](#).
8. Wash all pump parts with an appropriate cleaning solution at the cleaning product manufacturer's recommended temperature and concentration.
9. Rinse all pump parts again with water and allow them to dry.
10. Inspect all pump parts and reclean if needed.

Note

Any damaged rubber parts **must** be replaced as they could harbor microorganisms that can contaminate the fluid.

11. Immerse all pump parts in an appropriate sanitizer before assembly. Take the pump parts out of the sanitizer one-by-one as needed.
12. Lubricate the moving pump parts and o-rings, packings, and seals with appropriate waterproof sanitary lubricant.
13. Circulate the sanitizing solution through the pump and the system prior to use.
14. **Ram-Mounted Pumps:** Clean all ram surfaces. Remove and clean the inflatable seal and ram plate. See Manual 3A0591.

Tighten Threaded Connections

Before each use, check all hoses for wear or damage. Replace as necessary. Check that all connections are tight and leak-free.

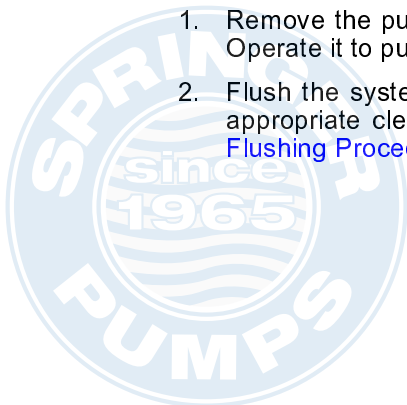

3A0733P

Tel: 866-777-6060
Fax: 866-777-6383

Springer Pumps, LLC

Website: www.springerpumps.com
Int'l: +001 267 404 2910

Troubleshooting

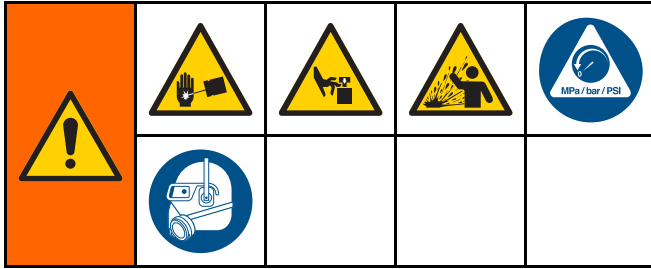

1. Follow the [Pressure Relief Procedure, page 8](#) .
2. Check all possible remedies in the Troubleshooting Chart before disassembling the pump.

Problem	Cause	Solution
Pump fails to operate.	Restricted air line or inadequate air supply.	Clear air line or increase air supply.
	Insufficient air pressure; closed or clogged air valves, etc.	Open or clean air valves, etc.
	Exhausted fluid supply.	Refill fluid supply.
	Damaged air motor.	Service.
Pump operates, but output low on both strokes.	Restricted air line or inadequate air supply.	Clear air line or increase air supply.
	Insufficient air pressure; closed or clogged air valves, etc.	Open or clean air valves, etc.
	Exhausted fluid supply.	Refill fluid supply.
	Obstructed fluid line, valves, dispensing valve, etc.	Clear. Relieve pressure and disconnect fluid line. Turn on air. If pump starts, the fluid line is clogged.
	Worn throat packing (105).	Replace throat packing.
	Damaged cylinder o-ring (104).	Replace o-ring.
Pump operates, but output low on down stroke.	Held open or worn fluid inlet valve.	Clear or service fluid inlet valve.
	Damaged cylinder o-ring (104).	Replace o-ring.
Pump operates, but output low on up stroke.	Held open or worn fluid piston or seal (120).	Clear or service fluid piston or seal.
Erratic or accelerated operation.	Exhausted fluid supply.	Refill fluid supply.
	Held open or worn fluid inlet valve.	Clear or service fluid inlet valve.
	Held open or worn fluid piston or seal (120).	Clear or service fluid piston or seal.

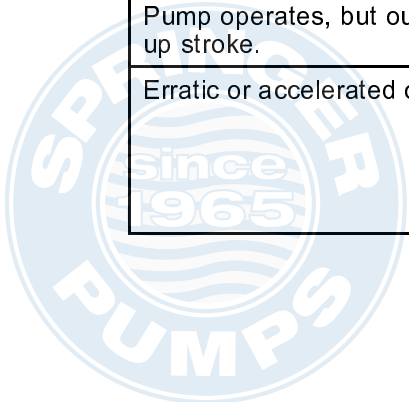

Priming Piston Service

Disconnect the Pump

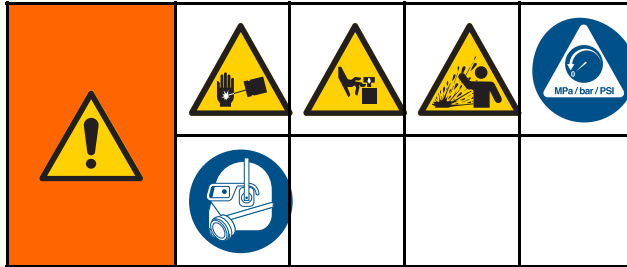

1. Remove the pump from the fluid container. Operate it to pump out as much fluid as possible.
2. Follow the [Pressure Relief Procedure, page 8](#).
3. **Ram-mounted pumps:** Remove the three clamps (C) holding the pump to the ram plate. Raise ram to lift pump.

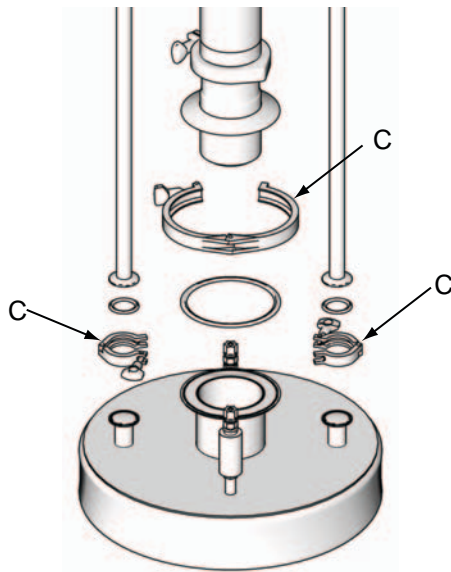

ti16567a

Figure 2 Remove the clamps.

4. Remove the fluid hoses from the pump.
5. Release the upper clamp (123) holding the displacement pump to the tie rod plate (122).
6. Slide the pump down from the air motor. Tilt the pump and pull the displacement rod (117) out of the coupler (C). Remove the gasket (102).
Note: Be careful not to scratch the displacement rod.

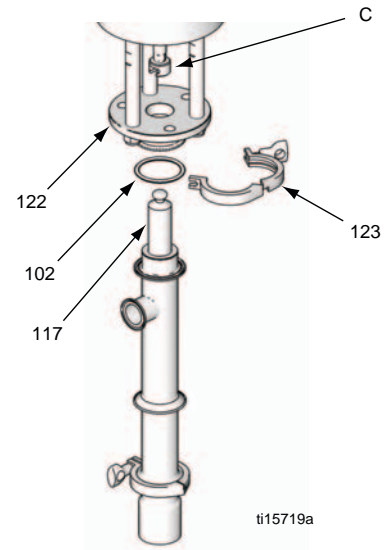

ti15719a

Figure 3 Remove displacement pump.

Disassemble the Pump

Note: Pump Repair Kit 24G550 is available. Purchase the kit separately. Kit parts are marked with an *.

1. Remove the retaining pin (116) from the connecting rod (109). Slide off the priming piston (108).
2. Release the lower clamp (123) to remove the intake valve housing (107) from the pump cylinder (101). Remove the gasket (102).
3. Remove the poppet (114), spring (113), and valve stop (111) off the connecting rod (109).
4. Remove the bearing (112) from the center of the valve stop (111).
5. Remove the packings (115) from the center of the poppet (114).

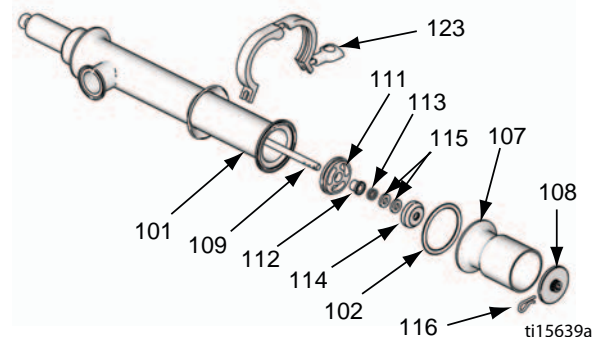

ti15639a

Figure 4 Remove priming piston.

6. Push the displacement rod (117) out through the bottom of the cylinder (101).

Priming Piston Service

7. Remove the retaining pin (118), o-ring (119), and ball (110). Pull the connecting rod (109) from the displacement rod (117). Remove the seal (120).

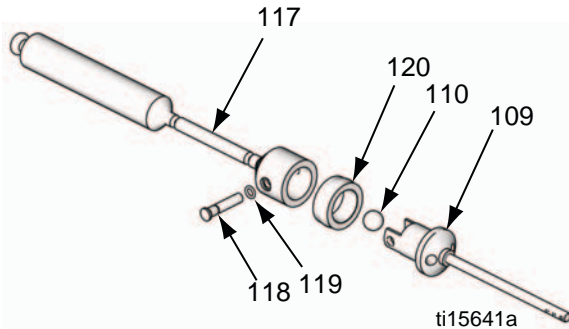

Figure 5 Disassemble piston valve.

8. Remove the packing housing (103) from the top of the cylinder (101). Remove the bearing (106), packing (105), and o-ring (104).
9. Clean and inspect all parts. Refer to [Cleaning, page 9](#). Replace the parts as necessary.

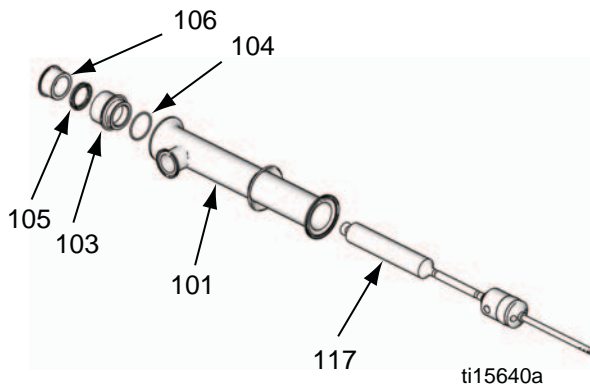

Figure 6 Remove packing housing.

Note: Lubricate the o-rings, throat packings, and piston seals with waterproof appropriate sanitary lubricant.

1. Install the v-block packing (105*) and bearing (106*) in the packing housing (103). The lips of the packing must face down into the housing, and the lip of the bearing must face up. Install the o-ring (104*) on the outside of the housing.
2. Install the seal (120*) on the piston valve housing at the top of the connecting rod (109). Place the ball (110) on the seat of the housing. Install the displacement rod (117) over the top of the connecting rod so the holes in both parts align. Secure with the retaining pin (118) and o-ring (119*).
3. Lubricate and place the packing housing (103) in the top of the cylinder.
4. Lubricate and slide the displacement rod (117) up through the cylinder so it protrudes from the packing housing (103). Model 24G746 only: Make sure the drip shield (121) is in place on the cylinder (101).
5. Lubricate and install the packings (115*) into the center of the poppet (114).
6. Lubricate and install the bearing (112*) into the center of the valve stop (111).
7. Slide the valve stop (111), spring (113*), and poppet (114) onto the connecting rod (109).
8. Install the gasket (102*) and the intake valve housing (107). Secure the housing (107) to the cylinder (101) with the clamp (123).
9. Install the priming piston (108) and retaining pin (116) on the connecting rod (109).
10. Slide the displacement rod (117) into the coupler. Then, attach the clamp (123) to hold the pump to the motor base.

Reassemble After Cleaning

Note: Any damaged parts must be replaced.



Double Ball Service

Disconnect the Pump

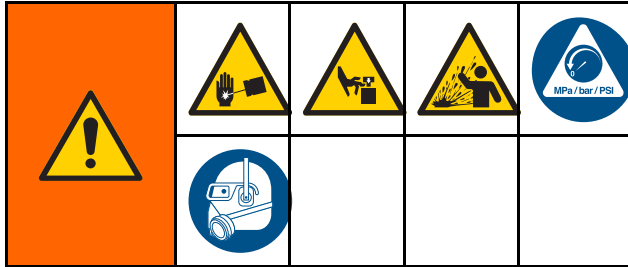

1. Remove the pump from the fluid container. Operate it to pump out as much fluid as possible.
2. Follow the [Pressure Relief Procedure, page 8](#).
3. **Ram-mounted pumps:** Remove the three clamps holding the pump to the ram plate. Raise ram to lift.

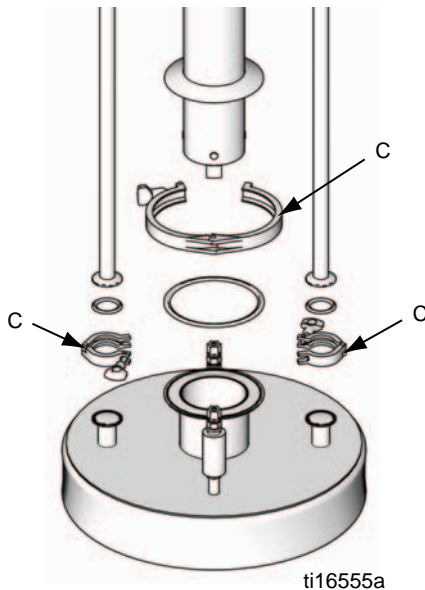

Figure 7 Remove the clamps.

4. Remove the fluid hoses from the pump.

5. Release the clamp (123) holding the displacement pump to the tie rod plate (122).
6. Slide the pump down from the air motor. Tilt the pump and pull the displacement rod (117) out of the coupler (C). Remove the gasket (102).

Note: Be careful not to scratch the displacement rod.

7. Carry the displacement pump to the bench for service.

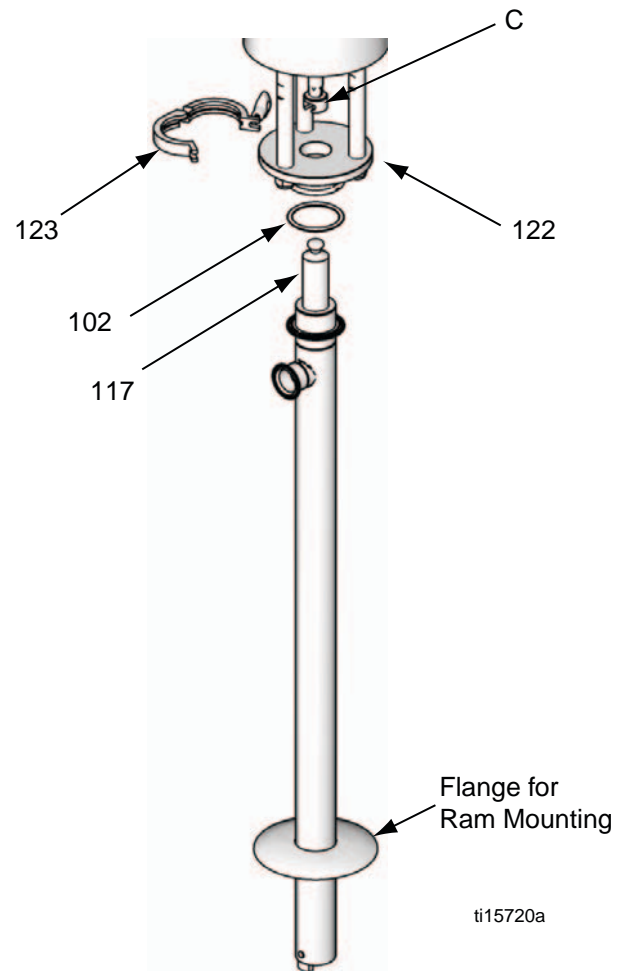

Figure 8 Remove displacement pump.



Disassemble the Pump

Note: Pump Repair Kits are available. Purchase the kit separately. See the Parts list for your displacement pump to select the correct kit for your displacement pump. Kit parts are marked with an *.

1. **Displacement Pump Models 24G748, 24G749, 24G750, 24G753, and 26A158:** Remove the two o-rings/retaining clips (119) and the retaining pin (127) from the inlet valve housing (107). See the parts drawing for [Double ball Displacement Pump Models 24G748, 24G749, 24G753, 24G750, and 26A158, page 19](#).
Displacement Pump Models 24G752 and 24G751: Remove the clamp (123) and gasket (102), then remove the adapter (129). See the parts drawing for [Double-Ball Displacement Pump Models 24G752 and 24G751, page 21](#).
2. Remove and disassemble the inlet valve assembly. Clean and inspect the parts.
3. Push the displacement rod (117) out through the bottom of the cylinder (101). Remove the piston housing (124) by removing the retaining pin (118) and the o-ring/retaining clip (119) and pulling the piston from the displacement rod. Disassemble, clean and inspect the parts.
4. Take the packing housing (103) off of the cylinder (101) and remove the bearing (106), packing (105), and o-ring (104).
5. Clean and inspect all parts. Refer to [Cleaning, page 9](#). Replace the parts as necessary.

Reassemble After Cleaning

Note: Any damaged rubber parts must be replaced as they could harbor microorganisms that can contaminate the fluid.

Note: Lubricate the o-rings, throat packings, and piston seals with waterproof appropriate sanitary lubricant.

1. **Displacement Pump Models 24G748, 24G749, 24G750, and 24G752:** Lubricate and install the piston seal (120*) on the piston housing (124).
Displacement Pump Models 24G751, 24G753, and 26A158: Lubricate and install the piston u-cup (128*) on the piston housing (124). The lips of the u-cup must face up. Install the spacer (120*) with its lip facing down.
2. Place the ball (110) on the seat of the piston housing (124). Install the housing in the displacement rod (117) so the holes in both parts align. Secure with the retaining pin (118) and one o-ring/retaining clip (119*).
3. Install the u-cup packing (105*) and throat bearing (106*) in the throat packing housing (103). The lips of the u-cup must face down into the housing, and the lip of the bearing must face up. Install the o-ring (104*) on the outside of the housing.
4. Lubricate and install the throat packing housing (103) in the top of the cylinder (101).
5. Lubricate and slide the displacement rod (117) up through the cylinder (101) so it protrudes from the top.
6. Install the o-ring (104*) on the intake valve housing (107). Place the ball (125) on the seat of the housing (107), and install the ball stop pin (126) in the top holes of the housing.
7. **Displacement Pump Models 24G748, 24G749, 24G750, 24G753, and 26A158:** Lubricate and slide the intake valve housing (107) up into the cylinder (101) until the bottom holes of the housing align with the holes in the cylinder. Secure using the retaining pin (118) and two o-rings/retaining clips (119*).
- Displacement Pump Models 24G752 and 24G751:** Lubricate and slide the intake valve housing (107) up into the cylinder (101). Install the gasket (102*), adapter (129), and clamp (123).



Parts

Complete Pump Models

24E836, 24E837, 24E838
 24E839, 24E840, 24F942
 24G739, 24G740, and 25A936

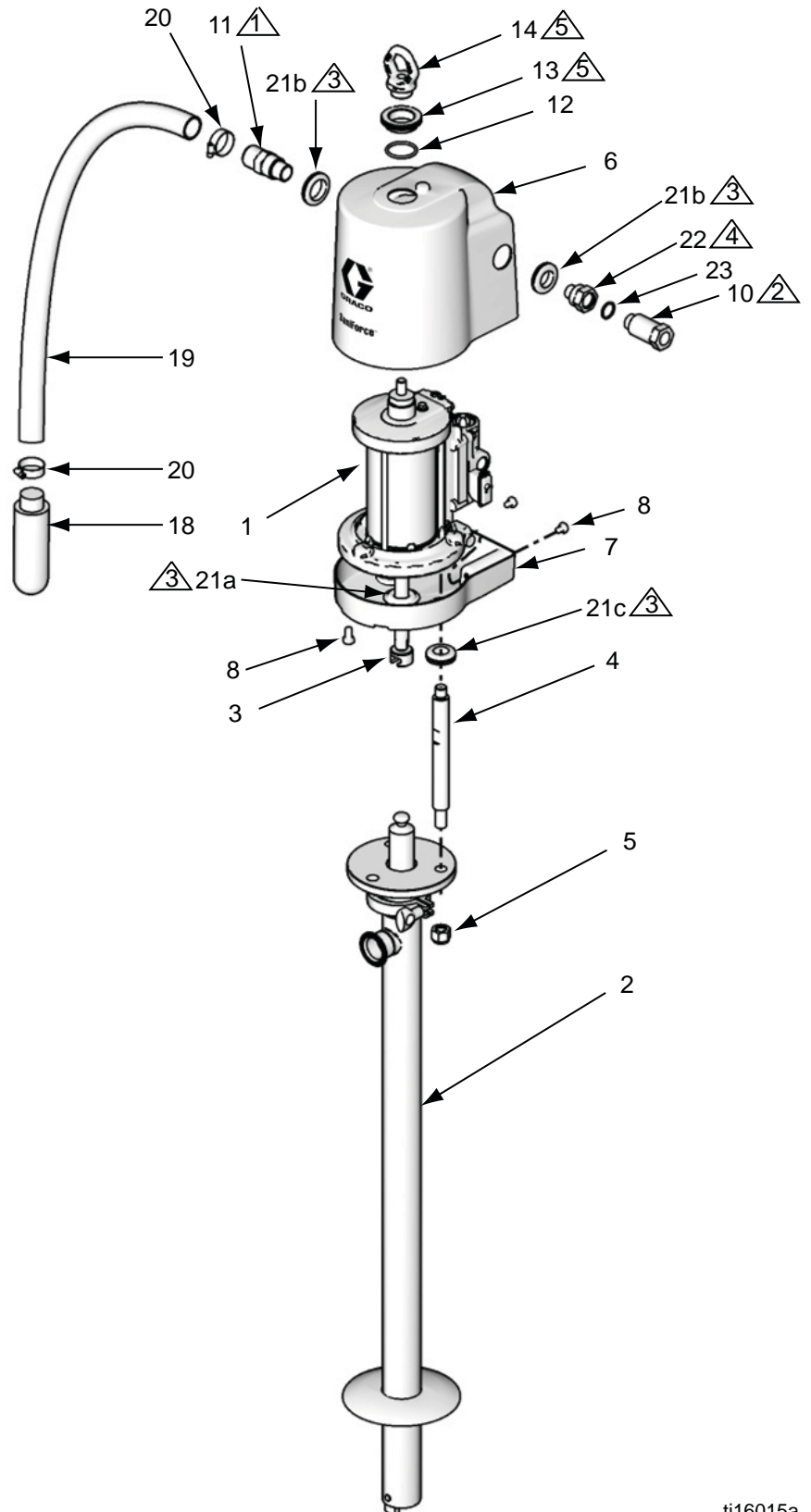

- △ 1 Apply PTFE tape to threads.
- △ 2 Hand tighten only.
- △ 3 Apply sanitary lubricant to ease assembly.
- △ 4 Apply medium-strength (blue) thread locker.
- △ 5 Apply an appropriate medium-strength thread locker on the lift ring (14) and nut (13) every time it is installed to prevent it from coming loose during operation. Torque to 30-36 ft-lb (41-49 N-m). Do not over tighten.



ti16015a

3A0733P

Tel: 866-777-6060
 Fax: 866-777-6383

Springer Pumps, LLC

Website: www.springerpumps.com
 Int'l: +001 267 404 2910

Kits

Complete Pump Models 24E836, 24E837, 24E838, 24E839, 24E840, 24F942, 24G739, 24G740, and 25A936

Ref.	Part	Description	Qty.	Ref.	Part	Description	Qty.
1	24G785	MOTOR, SaniForce; 3.5 in; see manual 3A1211	1	10	24G862	FITTING, air inlet, 1/2 npt, includes Ref. 23	1
2		DISPLACEMENT PUMP	1	11	16C946	FITTING, 3/4 npt	1
	24G747	Used on Pump Model 24G739; see page 18		12	165053	O-RING, PTFE	1
	24G748	Used on Pump Model 24G740; see page 20		13	16C306	NUT, hand	1
	24G746	Used on Pump Model 24E836; see page 18		14‡	16C009	RING, lift	1
	24G751	Used on Pump Model 24E837; see page 22		15▲	280574	LABEL, warning, not shown	1
	24G752	Used on Pump Model 24E838; see page 22		16‡	102218	CLAMP, toggle, fluid outlet; not shown	1
	24G753	Used on Pump Model 24E839; see page 20		17‡		GASKET, fluid outlet; not shown	1
	24G749	Used on Pump Model 24E840; see page 20			166130	Buna-N, used on pump models 24E836, 24E838, 24E840, and 24F942	
	24G750	Used on Pump Model 24F942; see page 20			680454	PTFE, used on pump models 24E837 and 24E839	
	26A158	Used on Pump Model 25A936; see page 20		18‡	512914	MUFFLER; <i>see Kits</i>	1
3	16A938	COUPLER	1	19‡	—	HOSE, exhaust; <i>see Kits</i>	1
4	16A947	TIE ROD, 7 in. (178 mm) between shoulders	3	20‡	101818	CLAMP, hose; <i>see Kits</i>	2
5	102216	NUT, lock, 5/8-11, sst	3	21	—	GROMMET; <i>see Kits</i>	6
6	16G464	SHIELD, upper; includes grommets (Ref. 21)	1	22	16G084	FITTING, air inlet, 1/2 npt	1
7	16G465	SHIELD, lower; includes fasteners (Ref. 8) and grommets (Ref. 21)	1	23	166702	O-RING, air inlet, buna-n, included with Ref. 10	1
8	118134	SCREW, cap; M8 x 1.25, sst	4	▲ Replacement Danger and Warning labels, tags, and cards are available at no cost.			

‡ Used on Models 24E836, 24E837, 24E838, 24E839, 24E840, 24F942, and 25A936 only. These parts are not used with Models 24G739 and 24G740.

Kits

Muffler Kit 16G390

Ref.	Part	Description	Qty.
18	512914	MUFFLER, polyethylene	2

Exhaust Assembly Kit 16G389

Ref.	Part	Description	Qty.
18	512914	MUFFLER, polyethylene	1
19	—	HOSE, exhaust, 6 ft.	1
20	101818	CLAMP, hose	2

Grommet Kit 16G628

Ref.	Part	Description	Qty.
21a*	—	GROMMET, air motor piston rod	1
21b	—	GROMMET, air fitting	2
21c	—	GROMMET, tie rod	3

* Order Kit 16H925 for qty. 3 of the piston rod grommet.

Shield Fastener Kit 16G432

Ref.	Part	Description	Qty.
8	118134	SCREW, cap, M8 x 1.25, sst	4

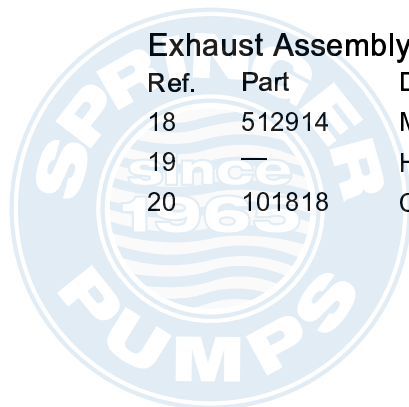

Priming Piston Displacement Pump Models 24G747 and 24G746

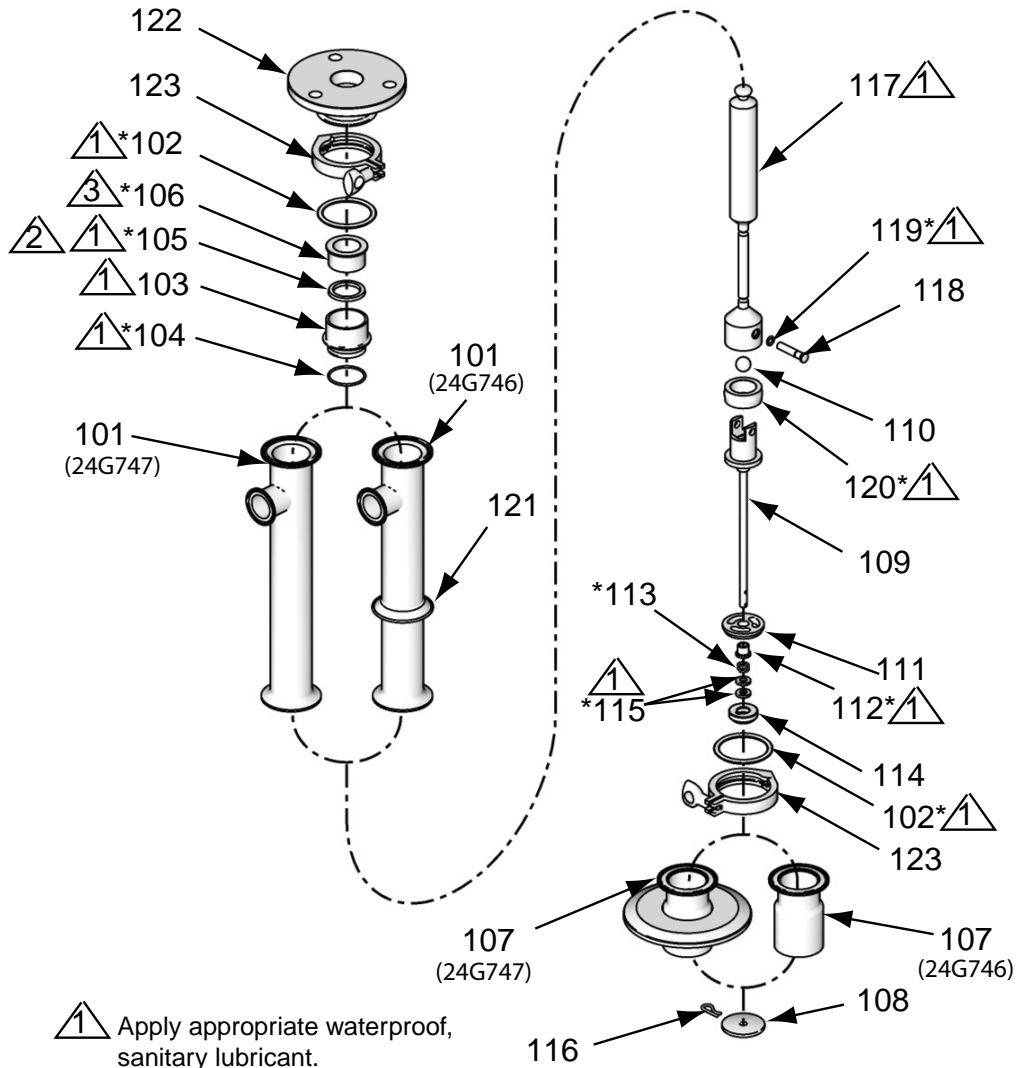

ti16157a

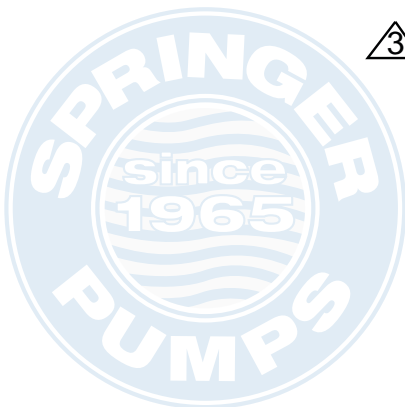

Priming Piston Displacement Pump Models 24G747 and 24G746

Ref.	Part	Description	Qty.	Ref.	Part	Description	Qty.
101	902980	CYLINDER, pump	1	113*	501095	SPRING, ball check	1
102*	166117	GASKET, 2 1/2 in. (64 mm), buna-n	2	114	604018	POPPET, inlet valve	1
103	180918	HOUSING, packing	1	115*	603778	PACKING, inlet valve, neoprene	2
104*	166119	O-RING, buna-n	1	116	604008	PIN, retaining, priming piston	1
105*	180238	V-PACKING, buna-n	1	117	902983	ROD, displacement	1
106*	180919	BEARING, sleeve	1	118	169845	PIN, retainer	1
107		HOUSING, inlet valve	1	119*	167972	O-RING	1
	16C193	Model 24G747		120*	167971	SEAL, piston, neoprene	1
	195213	Model 24G746		121	166129	SHIELD, drip; Model 24G746 only	1
108	195214	PISTON, priming	1	122	16A945	PLATE, tie rod	1
109	16C195	ROD, connecting	1	123	620223	CLAMP, 2 1/2 in. (64 mm)	2
110	103462	BALL, 3/4 in. (19 mm), stainless steel	1	130	172687	TAG, Instruction, not shown	1
111	195215	STOP, inlet valve	1				
112*	604016	BEARING, priming piston	1				

* Parts included in Repair Kit 24G550.



Double ball Displacement Pump Models 24G748, 24G749, 24G753, 24G750, and 26A158

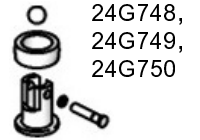
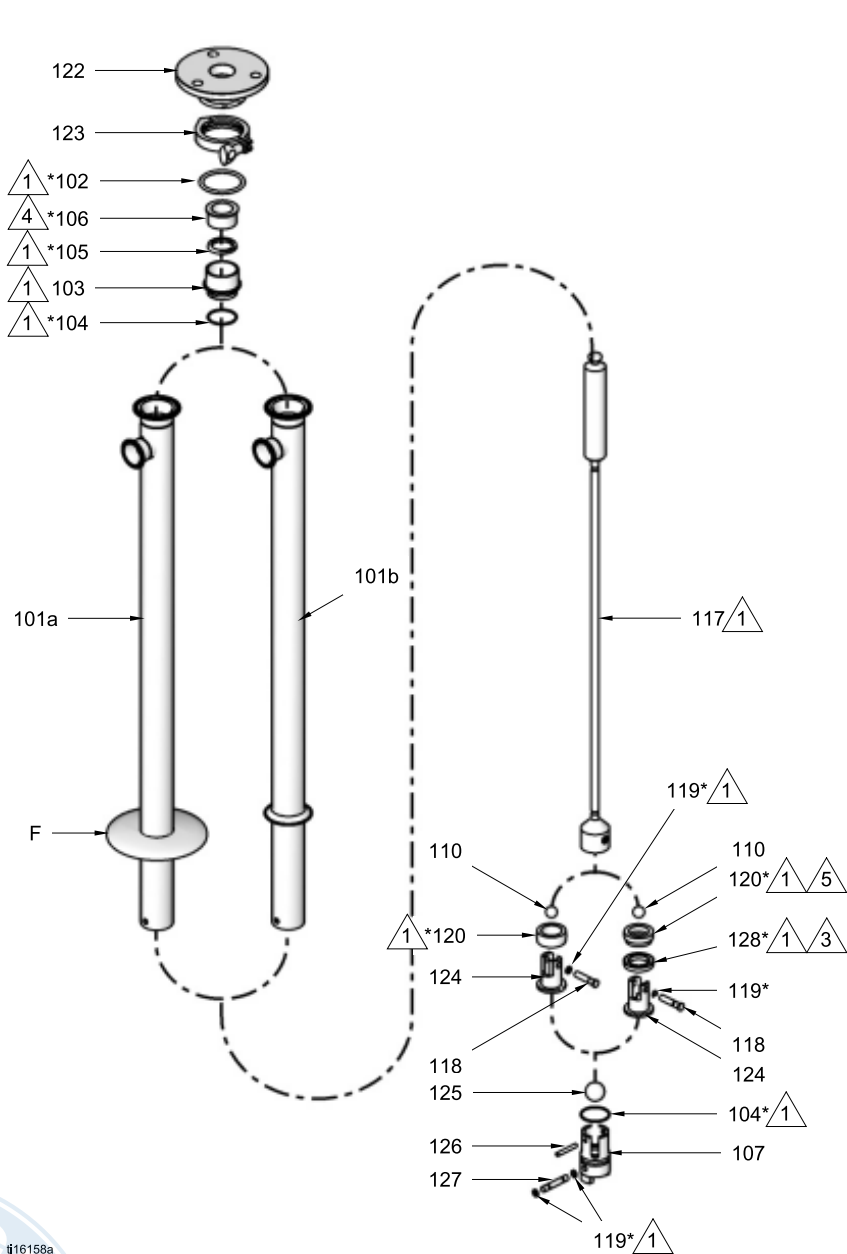

- F Flange for Ram Mounting
- △ Apply appropriate waterproof, sanitary lubricant.
 - △ Throat v-packing/u-cup lips must face DOWN.
 - △ Piston u-cup lips must face UP.
 - △ Bearing lip must face UP.
 - △ Spacer lips must face DOWN.

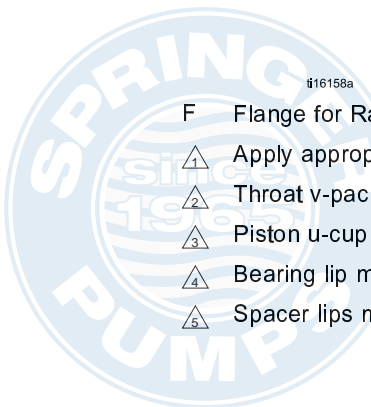

Double-Ball Displacement Pump Models 24G748, 24G749, and 24G750

Ref	Part	Description	Qty
101		CYLINDER, pump	1
101a	16G481	Model 24G748	
101b	207551	Model 24G749	
101b	16G482	Model 24G750	
102*	166117	GASKET, 2.5 in. (65 mm), buna-n	1
103	180918	HOUSING, packing	1
104*	166119	PACKING, o-ring; buna-n	2
105*	180238	V-PACKING, buna-n	1
106*	180919	BEARING, sleeve	1
107	167970	HOUSING, inlet valve	1
110	103462	BALL, 3/4 in. (19 mm), stainless steel	1
117		ROD, displacement	1
	207552	Models 24G748, and 24G749	
	16F986	Model 24G750	
118	169845	PIN, retaining, piston housing	1
119*	167972	O-RING	3
120*	167971	SEAL, piston, neoprene	1
121	166129	SHIELD, drip; Models 24G749 and 24G750 only	1
122	16A945	PLATE, tie rod	1
123	620223	CLAMP, 2.5 in. (64 mm)	1
124	169846	HOUSING, piston	1
125	103869	BALL, bearing, 1 1/4 in. (32 mm), stainless steel	1
126	169626	PIN, ball stop; straight, headless	1
127	167968	PIN, retaining, intake valve	1
130	172687	TAG, instruction, not shown	1

* Parts included in Repair Kit 24G546 .

Double ball Displacement Pump Models 24G753 and 26A158

Ref	Part	Description	Qty
101		CYLINDER, pump	1
101b	207551	Model 24G753	
101b	16G482	Model 26A158	
102*	502598	GASKET, 2.5 in. (65 mm) dia.; PTFE	1
103	180918	HOUSING, packing	1
104*	164846	PACKING, o-ring; PTFE	2
105*	605753	U-CUP, PTFE	1
106*	605752	BEARING, sleeve; PTFE	1
107	167970	HOUSING, inlet valve	1
110	103462	BALL, 3/4 in. (19 mm), stainless steel	1
117		ROD, displacement	1
	207552	Model 24G753	
	16F986	Model 26A158	
118	17F349	PIN, retaining, piston housing	1
119*	551008	RETAINING RING, sst	3
120*	605756	SPACER, PTFE	1
121	166129	SHIELD, drip, Model 24G753 only	1
122	16A945	PLATE, tie rod	1
123	620223	CLAMP, 2.5 in. (64 mm)	1
124	605837	HOUSING, piston	1
125	103869	BALL, bearing, 1 1/4 in. (32 mm), stainless steel	1
126	169626	PIN, ball stop; straight, headless	1
127	625916	PIN, retaining, intake valve	1
128*	605754	U-CUP, piston, PTFE	1
130	172687	TAG, instruction, not shown	1

* Parts included in Repair Kit 24G547.

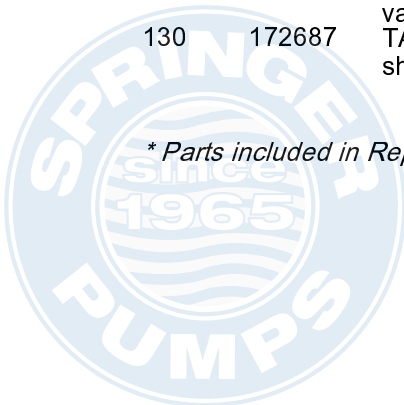

Double-Ball Displacement Pump Models 24G752 and 24G751

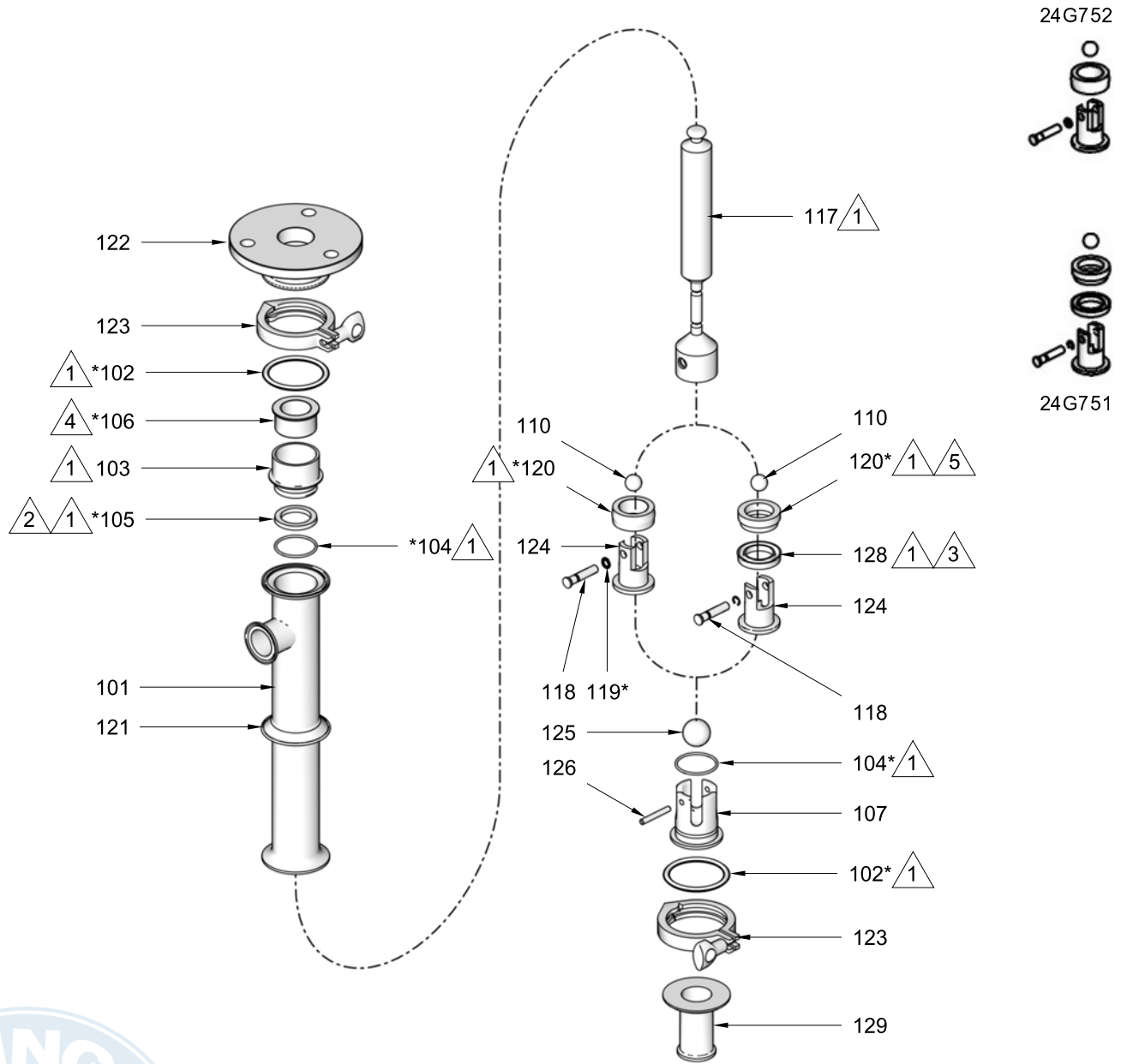

ti16160a

- △ Apply appropriate waterproof, sanitary lubricant.
- △ Throat v-packing/u-cup lips must face DOWN.
- △ Piston u-cup lips must face UP.
- △ Bearing lip must face UP.
- △ Spacer lips must face DOWN.

Double-Ball Displacement Pump Models 24G752

Ref	Part	Description	Qty
101	902980	CYLINDER, pump	1
102*	166117	GASKET, 2.5 in. (64 mm), buna-n	2
103	180918	HOUSING, packing	1
104*	166119	O-RING; buna-n	2
105*	178140	U-CUP, UHMWPE	1
106*	623059	BEARING, sleeve	1
107	902979	HOUSING, inlet valve	1
110	103462	BALL, 3/4 in. (19 mm), stainless steel	1
117	902981	ROD, displacement	1
118	169845	PIN, retaining, piston housing	1
119*	167972	O-RING	1
120	622142	SEAL, piston, UHMWPE	1
121	166129	SHIELD, drip	1
122	16A945	PLATE, tie rod	1
123	620223	CLAMP, 2.5 in. (64 mm)	2
124	169846	HOUSING, piston	1
125	103869	BALL, bearing, 1.25 in. (32 mm), stainless steel	1
126	169626	PIN, ball stop; straight headless	1
129	511192	ADAPTER, ferrule	1
130	172687	TAG, instruction, not shown	1

* Parts included in Repair Kit 24G548.

Double-Ball Displacement Pump Model 24G751

Ref	Part	Description	Qty
101	902980	CYLINDER, pump	1
102*	502598	GASKET, 2.5 in. (64 mm), PTFE	2
103	180918	HOUSING, packing	1
104*	166119	O-RING; PTFE	2
105*	605753	U-CUP; PTFE	1
106*	623059	BEARING, sleeve	1
107	902979	HOUSING, inlet valve	1
110	103462	BALL, 3/4 in. (19 mm), stainless steel	1
117	902981	ROD, displacement	1
118	17F349	PIN, retaining, piston housing	1
119*	551008	RETAINING RING, sst	1
120	605756	SPACER, PTFE	1
121	166129	SHIELD, drip	1
122	16A945	PLATE, tie rod	1
123	620223	CLAMP, 2.5 in. (64 mm)	2
124	605837	HOUSING, piston	1
125	103869	BALL, bearing, 1.25 in. (32 mm), stainless steel	1
126	169626	PIN, ball stop; straight headless	1
128*	605754	U-CUP, piston, PTFE; Model 24G751 only	1
129	511192	ADAPTER, ferrule	1
130	172687	TAG, instruction, not shown	1

* Parts included in Repair Kit 24G549.



Product Dimensions

Stubby Length

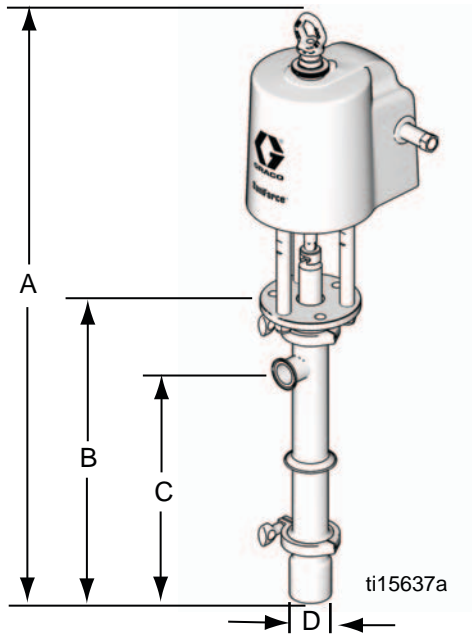

Drum and Bin Length

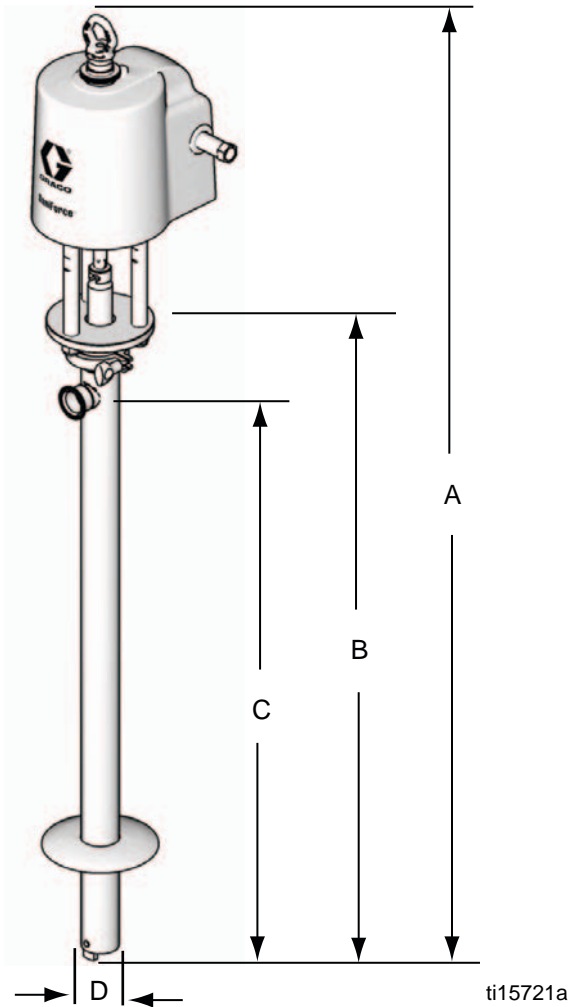

Model	Weight lb (kg)	Pump Style	A in. (cm)	B in. (cm)	C in. (cm)	D in. (cm)
24E836	34 (15)	Priming Piston Stubby	40.1 (102)*	20.6 (52)*	16.0 (41)*	2.5 (6.4)
24G739	35 (16)					
24E837	37 (17)	Double ball, Stubby	39.2 (100)	19.7 (50)	15.1 (38)	2.0 (5.1)
24E838	29 (13)					
24G740	38 (17)	Double Ball, Drum Length	60.5 (154)	41.0 (104)	36.4 (92)	2.0 (5.1)
24E839	37 (17)					
24E840	37 (17)					
24F942	40 (18)	Double ball, Bin Length	73.0 (185)	53.5 (136)	48.9 (124)	2.0 (5.1)
25A936						

* Add 2.5 in. (6.3 cm) for priming piston models to allow for full extension of the priming piston rod.

Performance chart

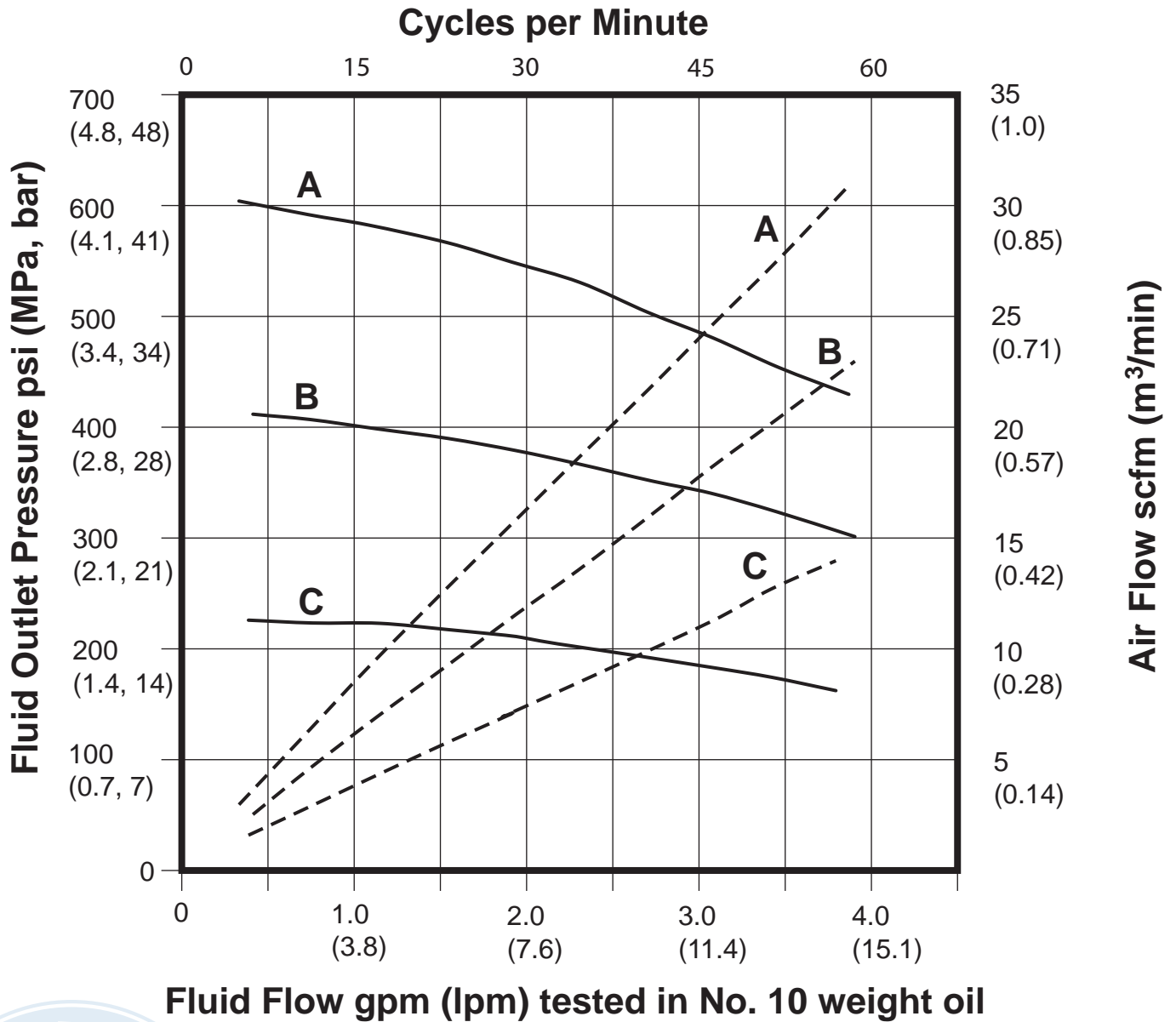

A = 100 psi (0.7 MPa, 7 bar)
 B = 70 psi (0.5 MPa, 5 bar)
 C = 40 psi (0.3 MPa, 3 bar)
 — = fluid flow
 - - - = air consumption

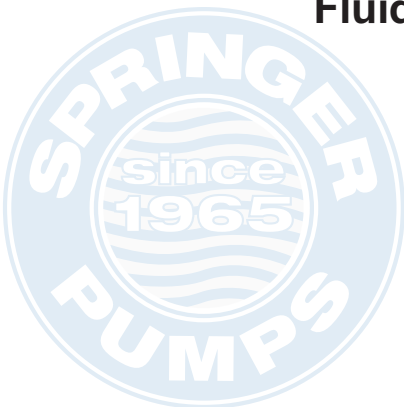

Technical Data

Maximum Fluid Working Pressure	650 psi (4.5 MPa, 44.8 bar)
Maximum Air Inlet Pressure	100 psi (0.7 MPa, 6.9 bar)
Maximum Recommended Pump Speed	60 cycles/min, 4 gpm (15 liters/min) delivery
Maximum Size Pumpable Solids	1/8 in. (3.2 mm)
Air Consumption	<i>See Performance Chart</i>
Pump Cycles per Gallon (3.8 Liters)	13.3
Ratio	6:1
Maximum Fluid Temperature	250°F (121°C)
Maximum Ambient Temperature (Air Motor)	120°F (49°C)
Air Inlet	1/2 npt (f)
Air Exhaust	3/4 npt (m)
Fluid Inlet Type	
	24E836 2.3 in (5.8 cm) Priming Piston
	24E837, 24E838 2.5 in. (6.3 cm) Clamp
	24E839 and 24E840 1.44 in. (3.6 cm) Slotted
	24G739 2.3 in (5.8 cm) Priming Piston with flange for 6 in. (15.2 cm) Clamp
	24G740, 24F942, 25A936 1.44 in. (3.6 cm) Slotted with flange for 6 in. (15.2 cm) Clamp
Fluid Outlet	1-1/2 in. (3.8 cm) Tri-clamp®
Weight	See Dimensions , page 25
Wetted Parts	316 Stainless Steel, Buna-N, Polychloroprene, Nitrile, Nylon, UHMWPE. Certain models have PTFE packings.
Sound data	
	Sound power* 78.5 dBA
	Sound pressure** 71.6 dBA

* Sound power at 70 psi (0.48 MPa, 4.8 bar), 20 cpm. Sound power measured per ISO-9614-2.

** Sound pressure was tested 3.28 feet (1 m) from equipment.

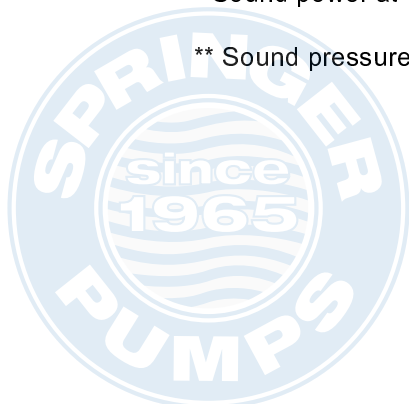

Graco Standard Warranty

Graco warrants all equipment referenced in this document which is manufactured by Graco and bearing its name to be free from defects in material and workmanship on the date of sale to the original purchaser for use. With the exception of any special, extended, or limited warranty published by Graco, Graco will, for a period of twelve months from the date of sale, repair or replace any part of the equipment determined by Graco to be defective. This warranty applies only when the equipment is installed, operated and maintained in accordance with Graco's written recommendations.

This warranty does not cover, and Graco shall not be liable for general wear and tear, or any malfunction, damage or wear caused by faulty installation, misapplication, abrasion, corrosion, inadequate or improper maintenance, negligence, accident, tampering, or substitution of non-Graco component parts. Nor shall Graco be liable for malfunction, damage or wear caused by the incompatibility of Graco equipment with structures, accessories, equipment or materials not supplied by Graco, or the improper design, manufacture, installation, operation or maintenance of structures, accessories, equipment or materials not supplied by Graco.

This warranty is conditioned upon the prepaid return of the equipment claimed to be defective to an authorized Graco distributor for verification of the claimed defect. If the claimed defect is verified, Graco will repair or replace free of charge any defective parts. The equipment will be returned to the original purchaser transportation prepaid. If inspection of the equipment does not disclose any defect in material or workmanship, repairs will be made at a reasonable charge, which charges may include the costs of parts, labor, and transportation.

THIS WARRANTY IS EXCLUSIVE, AND IS IN LIEU OF ANY OTHER WARRANTIES, EXPRESS OR IMPLIED, INCLUDING BUT NOT LIMITED TO WARRANTY OF MERCHANTABILITY OR WARRANTY OF FITNESS FOR A PARTICULAR PURPOSE.

Graco's sole obligation and buyer's sole remedy for any breach of warranty shall be as set forth above. The buyer agrees that no other remedy (including, but not limited to, incidental or consequential damages for lost profits, lost sales, injury to person or property, or any other incidental or consequential loss) shall be available. Any action for breach of warranty must be brought within two (2) years of the date of sale.

GRACO MAKES NO WARRANTY, AND DISCLAIMS ALL IMPLIED WARRANTIES OF MERCHANTABILITY AND FITNESS FOR A PARTICULAR PURPOSE, IN CONNECTION WITH ACCESSORIES, EQUIPMENT, MATERIALS OR COMPONENTS SOLD BUT NOT MANUFACTURED BY GRACO. These items sold, but not manufactured by Graco (such as electric motors, switches, hose, etc.), are subject to the warranty, if any, of their manufacturer. Graco will provide purchaser with reasonable assistance in making any claim for breach of these warranties.

In no event will Graco be liable for indirect, incidental, special or consequential damages resulting from Graco supplying equipment hereunder, or the furnishing, performance, or use of any products or other goods sold hereto, whether due to a breach of contract, breach of warranty, the negligence of Graco, or otherwise.

FOR GRACO CANADA CUSTOMERS

The Parties acknowledge that they have required that the present document, as well as all documents, notices and legal proceedings entered into, given or instituted pursuant hereto or relating directly or indirectly hereto, be drawn up in English. Les parties reconnaissent avoir convenu que la rédaction du présente document sera en Anglais, ainsi que tous documents, avis et procédures judiciaires exécutés, donnés ou intentés, à la suite de ou en rapport, directement ou indirectement, avec les procédures concernées.

Graco Information

For the latest information about Graco products, visit www.graco.com.
For patent information, see www.graco.com/patents.

To place an order, contact your Graco Distributor or call to identify the nearest distributor.

Phone: 612-623-6921 or Toll Free: 1-800-328-0211 Fax: 612-378-3505

All written and visual data contained in this document reflects the latest product information available at the time of publication.

Graco reserves the right to make changes at any time without notice.
Original Instructions. This manual contains English. MM 3A0733

Graco Headquarters: Minneapolis
International Offices: Belgium, China, Japan, Korea

GRACO INC. AND SUBSIDIARIES • P.O. BOX 1441 • MINNEAPOLIS MN 55440-1441 • USA
Copyright 2014, Graco Inc. All Graco manufacturing locations are registered to ISO 9001.

www.graco.com
Revision P, September 2018

