

Model 3P9XHR

## 3" Engine Driven Self-Priming Portable High Pressure Pumps

- **Cast Aluminum Construction with Cast Iron Diffusers**
- **EPDM/EPR Mechanical Seals**
- **Optional Viton® Seal and Elastomers Available**
- **3" Cast Iron Suction & Discharge Male NPT Port Sizes**
- **Maximum Flow up to 185 GPM**
- **Maximum Head up to 89 PSI**
- **Maximum Lift to 26 Ft.**
- **One Tool Serviceability**
- **Utilized for Fire Protection or Irrigation**
- **Discharge Port Rotates in 90° Increments**
- **Engine Options: Honda, LCT Storm Force Gasoline or Hatz Diesel Engines**
- **Optional High Pressure Hose Kit and Wheel Kit Available**



Model 3P9XLR

IPT 3" Self-Priming Engine Driven Portable High Pressure pumps are cast aluminum construction with cast iron volute and male NPT ports. Pump applications include fire protection, agricultural spraying, and irrigation. These pumps are available with a wide choice of standard and heavy duty gasoline or diesel fueled engines. These pumps feature closed cast aluminum impeller. All models come equipped with EPDM/EPR elastomers and seals. Most models include a heavy duty steel roll frame.

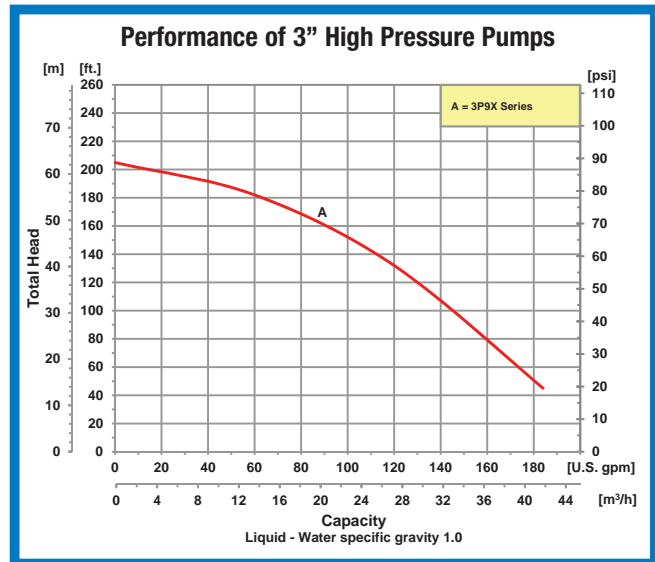

400 Spring Street • Royersford, PA 19468 USA

[www.amtpump.com](http://www.amtpump.com) • 888-amt-pump (268-7867)

For use with nonflammable liquids compatible with pump component materials. Viton® and Teflon® are registered trademarks of E. I. DuPont.

FIRE-5



# 3" Self-Priming Portable High Pressure Pumps

## Pump Dimensional & Specification Data

Model	HP Class	Curve	Port	Driver	Seal	Run Time (Hours)	Tank Size (Gal/Ltr.)	Ship Wt. (Lbs.)
3P9XLR	8 HP	A	3" NPT	LCT 306CC▲	EPDM/EPR/CAR/CER	2.2	0.95/3.6	145
3P9XHR	8 HP	A	3" NPT	Honda GX270▲	EPDM/EPR/CAR/CER	2.5	1.40/5.2	145
3P9XZR	8 HP	A	3" NPT	Hatz 1B40**▲	EPDM/EPR/CAR/CER	1.9	1.32/5.0	240

Construction: Cast Aluminum with Cast Iron Components

++ 12V DC Electric Start (Battery Not Included)

▲ Oil Alert Included

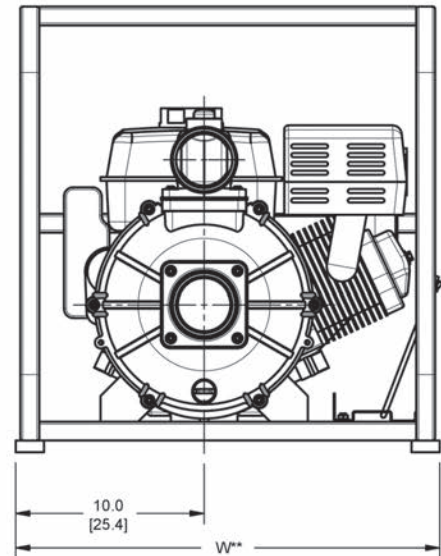
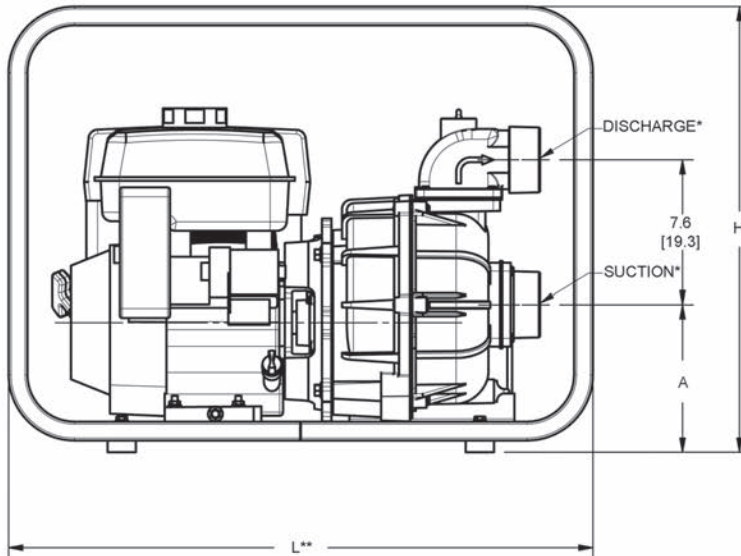

Model	DIS*	SUC*	L**	W**	H
3P9X Series	3	3	31.0 [78.7]	22.5 [57.1]	23.6 [60.0]

Model	A
Gas/Diesel 3P9X	7.8 [19.8]

(\*) Standard NPT (Male) Pipe Thread.

(\*\*) This dimension may vary due to engine manufacturer's specifications.

NOTE: Dimensions are in inches (centimeters) and have a tolerance of  $\pm 1/8"$ .

## Standard Features

- Aluminum Closed Impeller and Cast Iron Volute—Die Cast Aluminum Pump
- Large Pump Casing Increases Capacity
- Built-in Check Valve for Fast Priming
- Removable/Replaceable Cast Iron Suction & Discharge Flanges
- 3" Male NPT Discharge Port Rotates in 90° Increments
- EPDM/EPR Seal with Carbon and Ceramic Faces with Optional Viton® Seals and Elastomers
- One Tool Serviceability, Tool Included with Engine Driven Models (Not with Kits)
- Choice of LCT Storm Force, Honda Gasoline or Hatz Diesel Engines
- Includes Strainer and Rubber Foot Mounting
- Maximum Temperature 180° F
- Pedestal Versions Available
- Optional High Pressure Hose Kit and Wheel Kit Available
- QSP – Quick Ship Pumps



A Gorman-Rupp Company

Manufacturer of AMT & IPT Pumps

400 Spring Street • Royersford, PA 19468 USA

[www.amtpump.com](http://www.amtpump.com) • 888-amt-pump (268-7867)

The Gorman-Rupp Company reserves the right to discontinue any model or change specifications at any time without incurring any obligation.

©2012 American Machine and Tool Company. All rights reserved.



GORMAN-RUPP®

0421

FIRE-6

Tel: 866-777-6060

Fax: 866-777-6383

Springer Pumps, LLC

Website: [www.springerpumps.com](http://www.springerpumps.com)

Int'l: +001 267 404 2910