

# 1" Self-Priming Engine Driven Utility Pumps

Model 1G4XHR



- **Aluminum Construction**
- **Buna-N Mechanical Seal and O-Ring**
- **1" NPT Port Sizes**
- **Portable, Lightweight**
- **Solids Handling and Dirty Water Design**
- **Semi-Open, Clog Resistant Impeller**
- **Engine 4-Cycle Options:**
  - ◆ **Model 1G4XHR: Honda GX120**

The AMT/IPT line of Engine Driven Utility pumps offers economy, durability, portability and performance all in one neat package. Ideal for general purpose dirty water dewatering, irrigation, spraying, washdown and agricultural applications. Pumps are designed to handle liquids with solids content or dissolved solids and debris.

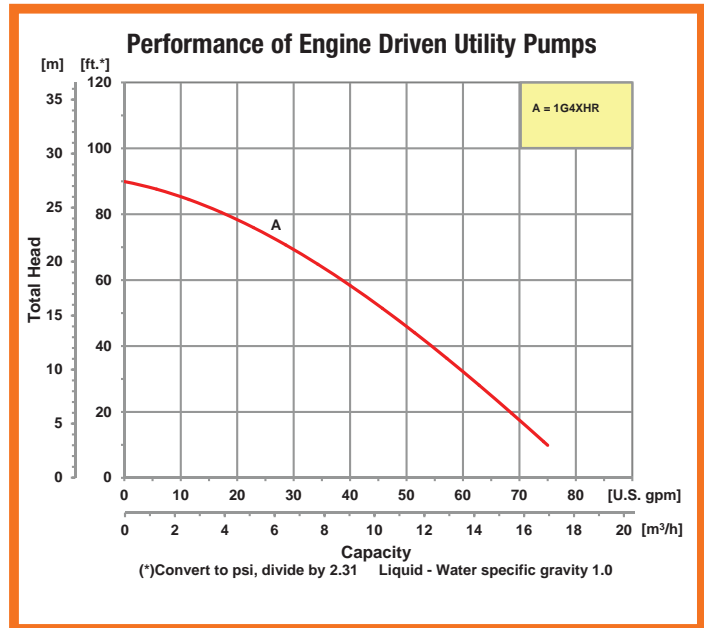
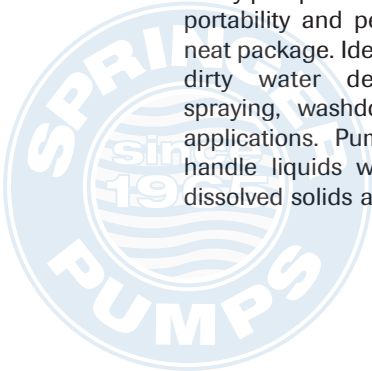

400 Spring Street • Royersford, PA 19468 USA

[www.amtpump.com](http://www.amtpump.com) • 888-amt-pump (268-7867)

For use with nonflammable liquids compatible with pump component materials. Viton® and Teflon® are registered trademarks of E. I. DuPont.

ENG-1

## 1" Utility Pump

Model	Curve	Driver	Run Time (Hours)	Tank Size (Gal/Ltr.)	Ship Wt. (Lbs.)
1G4XHR	A	Honda GX120	2.0	0.52/2.0	50

Construction: Cast Aluminum

Maximum Solids Handling Capacity: 1/4" Diameter

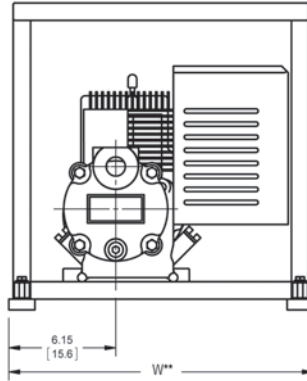
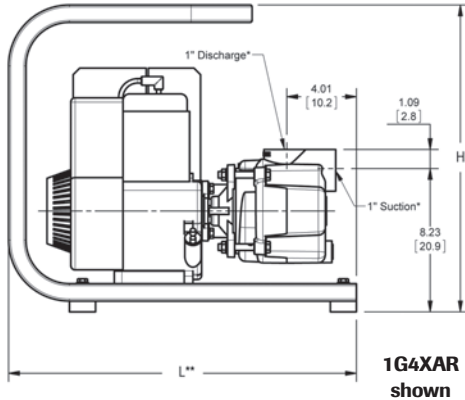

### Standard Features

- (2) Garden Hose Adapters
- Buna-N Mechanical Seal and O-ring
- O-ring Casing Seal
- Semi-open, Clog Resistant Impeller
- Self-priming to 15 Ft.
- Maximum Temperature 180° F
- Maximum Working Pressure 75 PSI
- Delivers up to 39 PSI
- Dual Volute Design
- Maximum of 75 GPM
- Includes Heavy Duty Steel Roll Frame
- QSP – Quick Ship Pump

Model	HP Class ♦	Curve	SUC*	DIS*	L**	W**	H
1G4XHR	4 HP	A	1	1	20.0 [50.8]	17.5 [44.4]	17.6 [44.7]

♦ HP Class represents market category and is not intended to define actual horsepower.

(\*) Standard NPT (Female) pipe thread.

(\*\*) This dimension may vary due to engine manufacturer's specifications.

NOTE: Dimensions are in inches (centimeters) and have a tolerance of  $\pm 1/8"$ .



Manufacturer of AMT & IPT Pumps

400 Spring Street • Royersford, PA 19468 USA

[www.amtpump.com](http://www.amtpump.com) • 888-amt-pump (268-7867)

The Gorman-Rupp Company reserves the right to discontinue any model or change specifications at any time without incurring any obligation.  
©2012 American Machine and Tool Company. All rights reserved.



0520

ENG-2

Tel: 866-777-6060

Fax: 866-777-6383

Springer Pumps, LLC

Website: [www.springerpumps.com](http://www.springerpumps.com)

Int'l: +001 267 404 2910