

Pump Accessories

3 HP Heavy Duty Steel
Roll Frame Assembly

- **Heavy Duty Roll Frame Assemblies with Scratch Resistant Powder Coated Steel**
- **Mounting Base allows for Simplified Installation on 182/184/215JM Framed Electric Pumps**
- **Wheel Kit Designed for 3 HP to 8 HP Steel Roll Cages**
- **Pedestal Pump Adapters Used with Pumps that Require NEMA 56c & 56J Frame Motors**



5 HP Heavy Duty
Steel Roll Frame Assembly



Wheel Kit



Mounting Base



400 Spring Street • Royersford, PA 19468 USA

www.amtpump.com • 888-amt-pump (268-7867)

For use with nonflammable liquids compatible with pump component materials. Viton® and Teflon® are registered trademarks of E. I. DuPont.

ACC-5

Tel: 866-777-6060
Fax: 866-777-6383

Springer Pumps, LLC

Website: www.springerpumps.com
Int'l: +001 267 404 2910

HEAVY DUTY ROLL FRAME

Part No.	Roll Frames	Ship Wt. (Lbs.)
2760-104-KO	3 HP/ 4 HP Frame	14
3120-IPT-KO	5 HP Frame for IPT Brand Pumps w/ 25mm Raising Blocks	25
3120-105-KO	5 HP w/ Rubber Feet	25
1696-100-KO	8 HP Frame w/ 33mm & 50mm Raising Blocks	30
1696-BAT-KO	12V DC Battery Tray Kit & Cable for 8 HP Frame	3

Heavy Duty Roll Frame is constructed with a scratch resistant powder coated steel.



WHEEL KIT

Part No.	Wheel Kit	Ship Wt. (Lbs.)
C402-90	Designed to fit any AMT Roll Frame	25

The wheel kit includes 10" semi-pneumatic tires on steel wheels with clamps and steel handle for universal mounting to frame.



MOUNTING BASE

Part No.	Mounting Base	Ship Wt. (Lbs.)
A200-90	Designed for 182/184/215JM Frames	50

- Mounting Base A200-90 allows for simplified installation of 145/182/184/215JM Framed Electric Pump Motors.
- Sturdy, rigid base to allow for pump stability and support of pump being mounted to base.
- Easily adjustable hole placement to allow for multiple pump models and specified above motors.

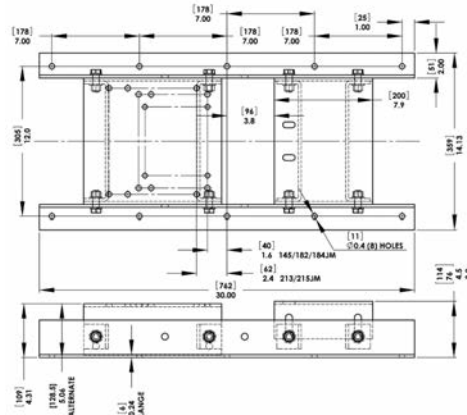

PEDESTAL PUMP ADAPTERS

Part No.	Pedestal Pump Adapters	Shaft	L	W	H	Ship Wt. (Lbs.)
3890-99	Pump Pedestal 56C—Keyed Shaft	3/16 x 3/16 x 1 Keyway	9.4 [23.8]	6.0 [15.2]	6.9 [17.5]	11
3891-99	Pump Pedestal 56J—Threaded Shaft	7/16-20UNF – 2A Threaded	9.3 [23.6]	6.0 [15.2]	6.9 [17.5]	11

Pedestal Pump Adapters allow for pumps to be installed with direct coupling drive or pulley drive and by electric motor or belt driven with engine.

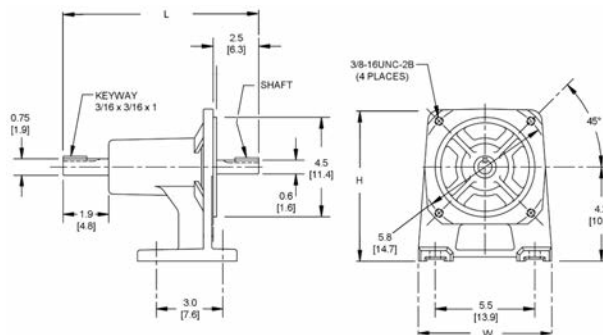

Manufacturer of AMT & IPT Pumps

400 Spring Street • Royersford, PA 19468 USA

www.amtpump.com • 888-amt-pump (268-7867)

The Gorman-Rupp Company reserves the right to discontinue any model or change specifications at any time without incurring any obligation. ©2012 American Machine and Tool Company. All rights reserved.



0613

ACC-6

Tel: 866-777-6060
Fax: 866-777-6383

Springer Pumps, LLC

Website: www.springerpumps.com
Int'l: +001 267 404 2910